

Catalogue 2017



ETERNO



MASTER

eternoviça









LEGENDA MATERIALI MATERIAL INDEX

I N O X	Acciaio Inox Stainless Steel
C U	Rame Copper
Z N	Zinco Zinc
M B P	Membrana bituminosa polimerica Polymeric bituminous membrane
G O M M A R U B B E R	Gomma vulcanizzata Vulcanized rubber
T P E	Elastomero termoplastico (gomma termoplastica) Thermoplastic elastomer (ther- moplastic rubber)
P V C	Cloruro in polivinile Polyvinyl chloride
T P O	Poliiolefine Polyolefin
T P E F L A T	Elastomero termoplastico (gomma termoplastica liscia) Thermoplastic elastomer (thermoplastic rubber flat)
E C B	Polimero etilene-bitumi Polymer ethylene-bitumen
P P	Polipropilene Polypropylene
P E	Polietilene Polyethylene

LEGENDA APPLICAZIONI APPLICATIONS INDEX

	Applicazione a colla/freddo con pennello Glue/cold application with brush
	Applicazione a fiamma Torch-on application
	Applicazione aria calda Hot air application
	Applicazione membrana liquida, cemento bicomponente con rullo Liquid waterproofing, cementitious bicomponent application with roll
	Articoli commercializzati Traded items

LEGENDA COMPATIBILITÀ PRODOTTI "ETERNO" E LIQUID COMPATIBILITY INDEX "ETERNO" AND "LIQUID" PRODUCTS

	M B P Membrane impermeabilizzanti bitume polimero: elastomeriche, elastoplastomeriche, plastomeriche Bitumen-polymer waterproofing membranes: elastomeric, elastoplastomeric, plastomeric
	E P D M Membrane in gomma EPDM EPDM rubber membranes
	P V C Membrane sintetiche in PVC PVC synthetic membranes
	T P O Membrane sintetiche in TPO TPO synthetic membranes
	E C B S B S Membrane sintetiche in ECB e bituminosi in SBS ECB synthetic and SBS bituminous membranes
	Qualsiasi tipo di membrana impermeabile Any type of waterproofing membrane
	Bitume ossidato, guaina liquida a freddo, cemento bicomponente Oxidized bitumen, cold liquid membrane, two-component cement
	Resine poliuretaniche ed epossidiche Polyurethane and epoxy resins

NB.: LE MISURE INDICATE NEL PRESENTE CATALOGO
SONO ESPRESSE IN MM, SALVO DIVERSE INDICAZIONI.
NB.: ALL MEASURES IN THIS CATALOGUE ARE
EXPRESSED IN MM, IF NOT OTHERWISE INDICATED.

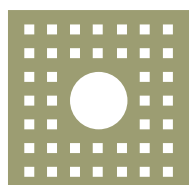

ETERNO

INTRODUZIONE GENERALE / INTRODUCTION	p.4	Bocchettone "Euro" in PVC con codolo h 250 mm e 400 mm "Euro" PVC roof drain with a 250 or 400 mm spigot	p.70
INTRODUZIONE ETERNO / ETERNO INTRODUCTION	p.14	Bocchettoni angolari in PVC PVC angular drains	p.72
ACCESSORI IN MEMBRANA BITUME POLIMERO / POLYMER-BITUMEN MEMBRANE ACCESSORIES	p.18	Bocchettoni angolari in PVC con codolo tondo e per poggiosi PVC angular drain with round spigot for balconies	p.74
Bocchettoni "Eterno" "Revolution" in MBP "Revolution" roof drains made of PBM	p.20	Esalatori in PVC semplici e doppi - Protezione circolare Simple wall and double wall PVC roof vents - protection collar	p.75
Angoli prefabbricati in membrana bituminosa polimerica Prefabricated corners made of polymeric bituminous membrane	p.23	Esalatori in PVC coibentato - Protezione circolare Insulated simple and double wall PVC roof vents - Protection collar	p.77
BOCCHETTONE "ETERNO" IN GOMMA EPDM / "ETERNO" EPDM RUBBER ROOF DRAIN	p.24	Angoli interni ed esterni in PVC PVC internal and external corner	p.78
Bocchettone in gomma EPDM con codolo h 200 mm "Eterno" EPDM rubber roof drain with a 200 mm spigot	p.28	Raccordi in PVC PVC base fitting	p.80
Bocchettone in gomma EPDM sifonato EPDM rubber roof drain with trap	p.29	Bocchetta PVC prova pressione PVC pressure test element	p.81
Anelli antiriflusso per bocchettoni in gomma EPDM h 200 mm Retro fit adaptors for EPDM roof drains h 200 mm	p.30	Profili perimetrali per membrane in PVC Profiles for PVC membranes	p.81
Prolunghe per bocchettoni in gomma EPDM Extensions for EPDM roof drain	p.31	ACCESSORI PER MANTI IMPERMEABILI IN POLIOLEFINE (TPO) / ACCESSORIES FOR TPO LAYERS	p.82
Bocchettone in gomma EPDM con codolo H 500/600/650 EPDM rubber roof drain with a 500/600/650 mm spigot	p.32	Bocchettone "Euro" in poliolefine (TPO) con codolo h 250 mm "Euro" Roof drain made of polyolefyne (TPO) with a 250 mm spigot	p.84
BOCCHETTONE "GENIUS" IN TPE / ROOF DRAIN "GENIUS" MADE OF TPE	p.34	Bocchettone angolare 90° - L 425 mm in poliolefine (TPO) Angular drain 90° - L 425 mm made of polyolefyne (TPO)	p.85
Bocchettone "Genius" in TPE con codolo h 250 mm e 400 mm "Genius" roof drain made of TPE with a 250 or 400 mm spigot	p.36	Esalatore in poliolefine (TPO) semplice e doppio - Protezione circolare Simple wall and double wall polyolefyne (TPO) roof vent - Protection collar	p.86
Bocchettone "Euro" in TPE con codolo h 250 mm e 400 mm "Euro" roof drain made of TPE with a 250 or 400 mm spigot	p.38	Raccordi per tubi in TPO - Raccordo conico in TPO TPO base fitting for pipes - TPO conical base fitting for pipes	p.88
Bocchettone "Mondial" in TPE con codolo h 170 mm e 250 mm "Mondial" roof drain made of TPE with a 170 or 250 mm spigot	p.39	Profili perimetrali per membrane in TPO Perimetral profiles for TPO membranes	p.89
BOCCHETTONE CON SCARICO VERTICALE O LATERALE IN TPE / TPE ROOF DRAIN WITH SIDE OR VERTICAL EXIT	p.40	Angoli interni ed esterni in TPO TPO internal and external corner	p.90
Bocchettone con scarico laterale o verticale in TPE TPE roof drain with side or vertical exit	p.44	Bocchettoni "Euro" in TPE flat con flangia liscia e codolo h 400 mm "Euro" TPE flat roof outlet with smooth flange and 400 mm spigot	p.92
BOCCHETTONI ANGOLARI IN TPE PER POGGIOLI / TPE ANGULAR DRAINS FOR BALCONIES	p.46	Bocchettoni angolari in TPE flat con flangia liscia TPE flat angular drain outlet with smooth flange	p.94
Bocchettoni angolari in TPE - Raccordi per bocchettone angolare TPE angular drains - Pipe adaptors for angular drain	p.50	Esalatore in TPE flat con flangia liscia - Protezione circolare TPE flat roof vent pipes with smooth flange - Protection collar	p.96
Bocchettone angolare in TPE con codolo tondo l 500 mm TPE angular drain with round spigot l 500 mm	p.52	Raccordo per tubi in TPE flat - Raccordo conico in TPE flat TPE flat pipes protection - TPE base fitting with smooth flange	p.97
Bocchettone angolare per poggiosi Angular drain for balconies	p.53	Angoli in TPE flat TPE flat corners	p.98
ESALATORI IN TPE PER MEMBRANE IN BITUME POLIMERO / TPE ROOF VENTS FOR BITUMINOUS MEMBRANES	p.54	Bocchettoni "Euro" in ECB con codolo h 250 mm "Euro" roof drain made of ECB with a 250 mm spigot	p.100
Esalatori in TPE semplici e doppi - Protezione circolare Simple wall and double wall TPE roof vents - protection collar	p.58	Bocchettone angolare l 425 mm sezione 100 x 65 mm in ECB - Bocchettone angolare in ECB con codolo tondo Angular drain l 425 mm section 100 x 65 mm made of ECB - Angular drain made of ECB with round spigot	p.101
Esalatore "Maxi" in TPE semplice e doppio Simple wall and double wall TPE "Maxi" roof vent	p.60	Esalatore in ECB - Protezione circolare Wall ECB roof vent pipe - Protection collar	p.102
Esalatore in TPE coibentato semplice e doppio - Protezione circolare Insulated simple wall and double wall TPE roof vent - protection collar	p.61	Raccordo per tubi in ECB - Raccordo conico in ECB ECB conical base fitting for pipes	p.103
Esalatore "Standard" per tegola canadese "Standard" type air vent for shingles	p.62	Angoli "Medio" e "Maxi" in ECB ECB "Medium" and "Maxi" corners	p.104
Raccordo per tubi in TPE e in gomma EPDM - Raccordo conico in TPE EPDM rubber and TPE base fittings for pipes - TPE conical base fitting for pipes	p.63	Parafoglie e paraghiaia, reti proteggi gronde Leaf-guards and gravel guards, eaves gutter guard	p.106
Angoli in TPE TPE corners	p.64	Salvasporgenze Eave-comb filler	p.112
Supporto orientabile in PP per rete parafulmine PP orientable support for lightning-conductor net	p.65	Pettini antinido Anti-nest comb	p.113
BOCCHETTONE PER MEMBRANE SINTETICHE / DRAIN HOLE FOR SYNTHETIC MEMBRANES	p.66		

Eterno Ivica è un'azienda che da oltre 60 anni opera nel mercato dell'edilizia producendo accessori e componenti destinati a molteplici settori, in ognuno dei quali l'azienda si distingue per l'elevato grado di specializzazione e innovazione delle soluzioni proposte.

L'ampia gamma dei prodotti, interamente progettata e prodotta in Italia, è articolata in 8 linee e comprende: supporti per pavimenti sopraelevati, sottostrutture da esterno per pavimenti in doghe, accessori per l'impermeabilizzazione di coperture piane con membrane liquide ed in rotolo, sistemi per la canalizzazione delle acque, attrezzature per la posa, silenziatori acustici e ventilazione degli ambienti, servizi e prodotti per l'isolamento acustico.

Eterno Ivica fa parte del gruppo Plastic Plus, con Italtronic e Plastic Planet. Fra le aziende del gruppo si sviluppano costanti sinergie sia in ambito produttivo che progettuale, volte a massimizzare i livelli di qualità dei prodotti, innovazione nello sviluppo, efficienza dei servizi. La sede del gruppo Eterno Ivica è ubicata a Padova su un'area di 10.000 mq, dei quali 6.000 coperti.

SUPERIOR
QUALITY FOR
BUILDING



Eterno Ivica is a company that for over 60 years has worked in the building market producing accessories and components for many sectors, in each of which the company is renowned for its high degree of specialization and innovation of the proposed solutions.

The wide range of products, designed and produced entirely in Italy, is divided into 8 lines and includes: support for raised flooring, substructures for outdoor decking, accessories for flat roofs waterproofing and liquid systems for sewage water, equipment for the installation, acoustic silencers and ventilation of rooms, services and products for soundproofing.

Eterno Ivica is part of the Plastic Plus Group, with Italtronic and Plastic Planet. Constant synergies have developed among the companies in the group both in the production as well as the project, aimed at maximizing the quality levels of products, innovation in the development, efficiency of service. The headquarters of the Eterno Ivica Group are located in Padova on an area of 10,000 square meters, of which 6,000 are covered.



LA NOSTRA STORIA

OUR HISTORY



1955

DAL 1955 FONDAMENTA SOLIDE

L'inizio di tutto è IVICA, che vuol dire Industria Veneta Idrofughi Catrami ed Affini. Ora l'attività aziendale comprende altri settori dell'edilizia, con la stessa voglia di essere specialisti assoluti. Sempre all'avanguardia in ogni specifica applicazione.

SINCE 1955 SOLID FOUNDATIONS

It all began with IVICA, which stands for "Industria Veneta Idrofughi Catrami ed Affini" (Venitian Industry Tar waterproofing and Allied Products). Now company activities include other building sectors, and we still focus on being absolute specialists. Always on the cutting edge with each specific application.

1955

NASCE I.V.I.C.A INDUSTRIA VENETA IDROFUGHI CATRAMI ED AFFINI

di Favero Ruggero "Industria Veneta Idrofughi Catrami ed Affini".

THE BIRTH OF I.V.I.C.A VENITIAN INDUSTRY TAR WATERPROOFING AND ALLIED PRODUCTS

"Industria Veneta Idrofughi Catrami ed Affini" (Venitian Industry Tar waterproofing and Allied Products) by Favero Ruggero.

1972



VIENE DEPOSITATO IL BREVETTO DEL BOCCHETTONE "ETERNO"

primo bocchettone di scarico per acque pluviali totalmente realizzato in gomma.

THE PATENT IS FILED FOR THE "ETERNO" DRAIN

the first roof drain for rainwater entirely made of rubber.



eterno·ivica

1973

NASCE LA SOCIETÀ ETERNO S.A.S.

che si dedicherà alla produzione di
"accessori per manti impermeabili".

THE COMPANY ETERNO S.A.S. WAS FOUNDED

dedicated to producing "accessories
for waterproof membranes".

"eterno"



1980

VIENE COSTITUITA
ETERNO IVICA S.P.A.
dalla fusione delle due
precedenti società.

ETERNO IVICA S.P.A.
WAS ESTABLISHED
by merging the former
two companies.

1988

IL MAXISOSTEGNO

Viene prodotto e presentato per la
prima volta in Italia un supporto per
pavimentazioni sopraelevate esterne,
regolabile in altezza.

THE MAXISOSTEGNO

A height-adjustable support system for
external raised paving was produced and
presented for the first time in Italy.



LA NOSTRA STORIA

OUR HISTORY

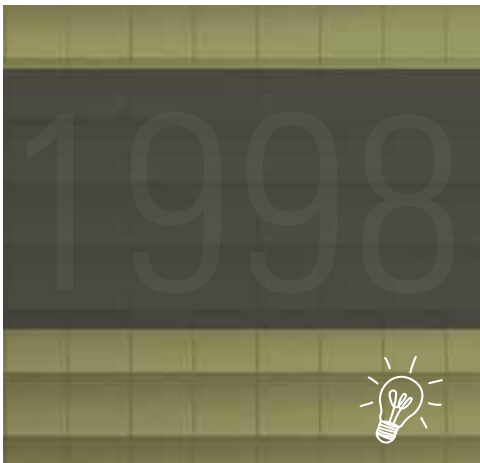

VIENE DEPOSITATO IL BREVETTO DEL "BOCCHETTONE "GENIUS"

Primo bocchettone di scarico per acque pluviali con "flangia forata".

THE PATENT WAS FILED FOR THE "GENIUS" DRAIN

The first roof drain for rainwater with a "perforated flange".

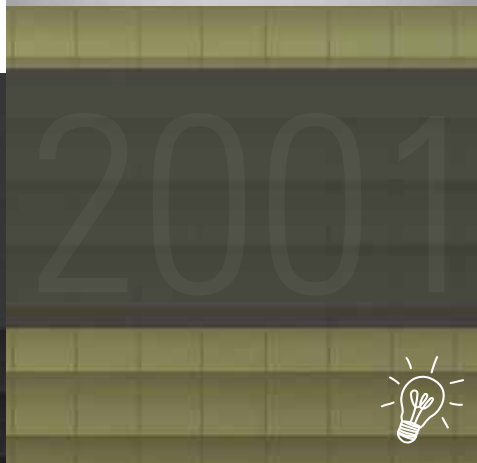
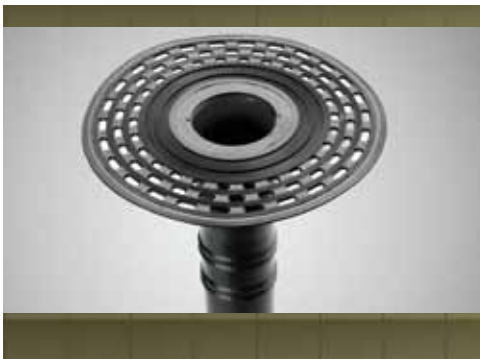

VIENE DEPOSITATO IL BREVETTO SUPPORTO AUTOLIVELLANTE

Viene depositato il brevetto del supporto "Eterno", primo e unico supporto per pavimentazioni sopraelevate esterne, regolabile in altezza, con testa basculante e autolivellante.

THE PATENT WAS FILED FOR THE SELF-LEVELING SUPPORT

The patent was filed for the first original height-adjustable support for external raised paving, with a self-leveling head.

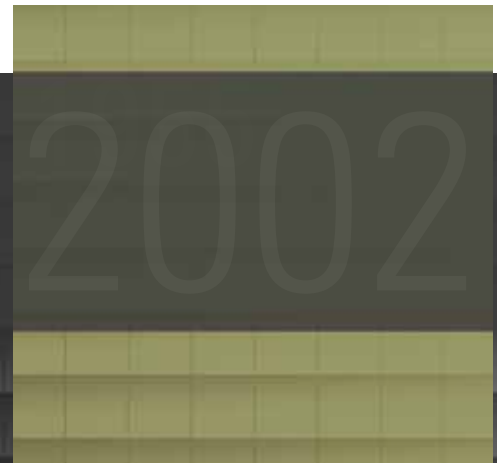

NASCE IL GRUPPO PLASTIC PLUS

costituito da Eterno Ivica, Italtronic e Plastic Planet, con lo scopo di condividere esperienze e conoscenze, al fine di creare importanti sinergie a livello organizzativo.

PLASTIC PLUS GROUP WAS ESTABLISHED

Eterno Ivica, Italtronic and Plastic Planet merged in order to share experiences and know-how and create important organizational synergies.





2003

COSTRUZIONE DELLA NUOVA SEDE

in Via Austria, nella Zona Industriale
di Padova.

NEW HEADQUARTERS WERE BUILT

in Via Austria, in the industrial area
of Padua.

2009

VIENE DEPOSITATO IL BREVETTO TESTA SUPPORTO (PP+GOMMA)

viene depositato il brevetto del primo
e unico supporto per pavimentazioni
sopraelevate esterne, con la testa in
bi-materiale (PP + gomma).

THE PATENT WAS FILED FOR THE HEAD SUPPORT (PP+RUBBER)

The patent was filed for the first original
support for external raised paving, with
bi-component PP+rubber head.



2010

NASCE LA LINEA NEW MAXI

Si rinnova la storica linea di supporti
regolabili in altezza "Maxisostegno" con
la nuova e moderna linea "New Maxi".

THE NEW MAXI LINE WAS CREATED

The historic line of height adjustable
supports "Maxisostegno" is renewed with
the new and modern line "New Maxi".



LA NOSTRA STORIA

OUR HISTORY



2011

NASCE LA LINEA LIQUID

Nasce l'innovativa linea di bocchettoni di scarico "LIQUID", appositamente studiata per l'applicazione con guaine liquide e resine mono/bicomponenti.

THE LIQUID LINE WAS CREATED

The innovative "LIQUID" roof drain line was created, specifically designed for application with liquid membranes and mono/bi-component resins.



2013

NASCE LA NUOVA LINEA ACUSTICA

È di quest'anno un importante investimento nel settore dell'isolamento acustico degli edifici, con la creazione e produzione della nuova linea di prodotti "Acustica".

THE NEW "ACOUSTIC" LINE WAS CREATED

This year important investment has been made in the field of sound insulation for buildings, with the creation and production of a new line of "Acoustic" products.

2014

ACQUISTATA STORICA SEDE ETERNO IVICA

in Via Prima Strada 20 a Padova la quale sarà oggetto di totale rifacimento.

ACQUIRED ETERNO IVICA'S HISTORICAL HEADQUARTERS

Located in Prima Strada str. 20, Padua, and will be totally renovated.





2015



VIENE DEPOSITATO
IL BREVETTO DEL TXT
primo prodotto acustico
interamente riciclato e riciclabile.

THE PATENT WAS FILED
FOR THE TXT
the first entirely recycled and
recyclable soundproofing product.

2015



VIENE DEPOSITATO
IL BREVETTO STAR.T
L'unico supporto regolabile in altezza
al mondo in grado di sopraelevare da
8 a 15 mm.

THE PATENT WAS FILED
FOR THE STAR.T
The only support in the world
adjustable from 8 to 15 mm.



2016



ACQUISTO SOCIETÀ
DANI SYSTEM E MARCHIO
RUMOR BLOCK

ACQUIRED DANI SYSTEM
COMPANY AND THE RUMOR
BLOCK BRAND

UN VIAGGIO NELLA QUALITÀ A 360°

A JOURNEY IN QUALITY AT 360°



L'obiettivo primario di Eterno Ivica è garantire la massima qualità, affidabilità e sicurezza. L'impegno rivolto al conseguimento della qualità e al miglioramento continuo, il controllo costante sulle materie prime e i prodotti finiti sottoposti a specifici test, l'attenzione alla qualità dei processi e all'orientamento verso il cliente sono dimostrati dalla Certificazione ISO 9001:2008. Eterno Ivica ha inoltre conseguito la Certificazione ISO 14001:2008 a dimostrazione del rispetto di tutti i requisiti normativi rilevanti per l'ambiente, l'ottimizzazione dei consumi energetici, l'utilizzo di materie prime non inquinanti e la gestione ottimale dello smaltimento dei rifiuti. Infine la Certificazione SA 8000 premia le politiche etiche orientate al rispetto dei diritti sociali in tutta la filiera produttiva.

The primary goal of Eterno Ivica is to ensure the highest quality, reliability and safety. The efforts aimed at achieving quality and continuous improvement, constant control on raw materials and finished products undergoing specific tests, attention to the quality of processes and the orientation towards the client are proven by the ISO Certification 9001: 2008. Eterno Ivica has also obtained the ISO 14001: 2008 certification demonstrating compliance with all regulatory requirements relevant to the environment, the optimization of energy consumption, the use of raw materials not polluting and optimal management of waste disposal. Finally, the SA 8000 Certification rewards ethical policies oriented with respect for social rights in the entire production chain.

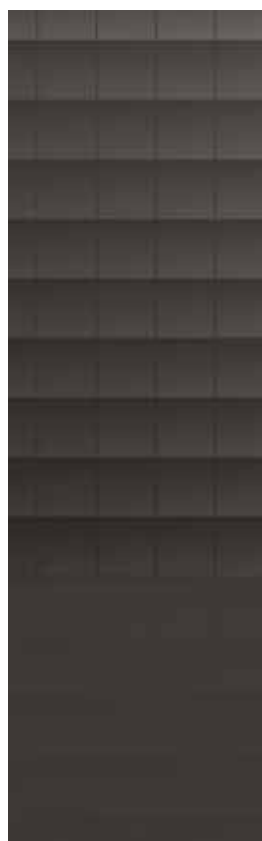



100% ETERNO IVICA,
100% MADE IN ITALY,
100% RICICLABILE

Tutti i prodotti Eterno Ivica sono progettati e interamente realizzati in Italia. Lo stile, il design, il gusto, la cura del dettaglio e l'eccellenza italiana contraddistinguono i nostri sistemi, distribuiti attraverso una rete di 30 distributori esclusivi e apprezzati in tutto il mondo.

L'intera produzione di Eterno Ivica è svolta internamente all'azienda, mediante 13 presse ad iniezione fino a 550 tonnellate, che lavorano a ciclo continuo, 6 giorni su 7. Il ciclo produttivo è completo, i prodotti escono pronti per la consegna.

100% ETERNO IVICA,
100% MADE IN ITALY,
100% RECYCLABLE

All Eterno Ivica products are designed and manufactured entirely in Italy. Style, design, taste, attention to detail and Italian excellence distinguish our systems, distributed through a network of 30 exclusive distributors and appreciated throughout the world.

The entire production of Eterno Ivica is performed in-house, using 13 injection molding machines up to 550 tons, which work around the clock, six days a week. The production cycle is complete, the products come out ready for delivery.

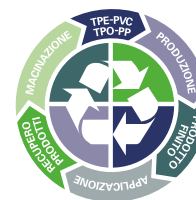

UNA STORIA FONDATA SULLE IMPERMEABILIZZAZIONI

A HISTORY FIRMLY- ROOTED IN THE FIELD OF WATERPROOFING

Quella di Eterno Ivica è la storia di specialisti assoluti delle impermeabilizzazioni. Tutto comincia negli anni '50 dall'esperienza di Ruggero Favero che dopo aver guidato un'azienda specializzata nella posa di membrane la IVICA (Industria Veneta Idrofughi Catrami ed Affini) fonda nel 1973 la Eterno SAS e nel 1980 nasce l'attuale ETERNO IVICA. I primi prodotti sono bocchettoni per guaine impermeabili, un campo di utilizzo che l'azienda continuerà a rivoluzionare e perfezionare. Oggi è il figlio di Ruggero, Gabriele Favero a guidare la Eterno Ivica, sempre all'avanguardia nell'evoluzione tecnica e tecnologica del settore.

The history of Eterno Ivica is one of experts operating in the field of waterproofing. It all dates back to the 1970s, when Ruggero Favero, after having gained experience with a company specializing in the installation of membranes, founded IVICA (Industria Veneta Idrofughi Catrami ed Affini). The company's first products were drain outlets for waterproof roofing felts, a range of products that the company would continue to revolutionize and perfect. The company is currently led by Ruggero's son, Gabriele Favero, who is dedicated to ensuring that Eterno Ivica will always remain at the forefront in terms of the industry's technical and technological developments.

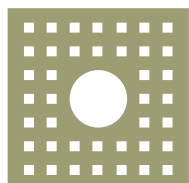

ET E R N O



RICERCA CONTINUA
E INNOVAZIONE
TECNOLOGICA
PER SISTEMI DI
IMPERMEABILIZZAZIONE
DI ALTISSIMA QUALITÀ

CONTINUOUS RESEARCH
AND TECHNOLOGICAL
INNOVATION FOR THE
HIGHEST QUALITY
WATERPROOFING
SYSTEMS





BOCCHETTONI
ANGOLARI IN TPE
RACCORDI PER
BOCCHETTONE
ANGOLARE

TPE ANGULAR
DRAINS - PIPE
ADAPTORS FOR
ANGULAR DRAIN

PAG
50

BOCCHETTONE
ANGOLARE PER
POGGIOLI

ANGULAR
DRAIN FOR
BALCONIES

PAG
53

PAG
40

BOCCHETTONE CON
SCARICO VERTICALE O
LATERALE IN TPE

TPE ROOF DRAIN
WITH SIDE OR
VERTICAL EXIT



Eterno Ivica, grazie a investimenti costanti in ricerca e sviluppo e un'attenzione irrinunciabile alla qualità, ha creato soluzioni innovative, funzionali ed efficaci, in grado di rispondere in maniera puntuale alle più variegate esigenze dell'edilizia moderna. I prodotti e i sistemi della gamma Eterno sono studiati e ingegnerizzati per esaltare la bellezza del progetto, massimizzare l'efficacia della costruzione, incrementare la durata e il valore degli edifici.

PAG
34BOCCHETTONE
"GENIUS" IN TPEROOF DRAIN "GENIUS"
MADE OF TPEPAG
22BOCCHETTONI "REVOLUTION"
IN MEMBRANA BITUMINOSA
POLIMERICA"REVOLUTION" ROOF
DRAINS MADE OF
POLYMERIC BITUMINOUS
MEMBRANE

Eterno Ivica, thanks to its constant investments in research and development and an indispensable attention to quality, has created innovative, functional and effective solutions, able to respond in a timely manner to the most varied demands of modern construction. Eterno products range and systems are designed and engineered to enhance the beauty of your project, maximize the effectiveness of construction, increasing the duration and value of the buildings.

ACCESSORI
IN MEMBRANA
BITUME POLIMERO

POLYMER-BITUMEN
MEMBRANE
ACCESSORIES

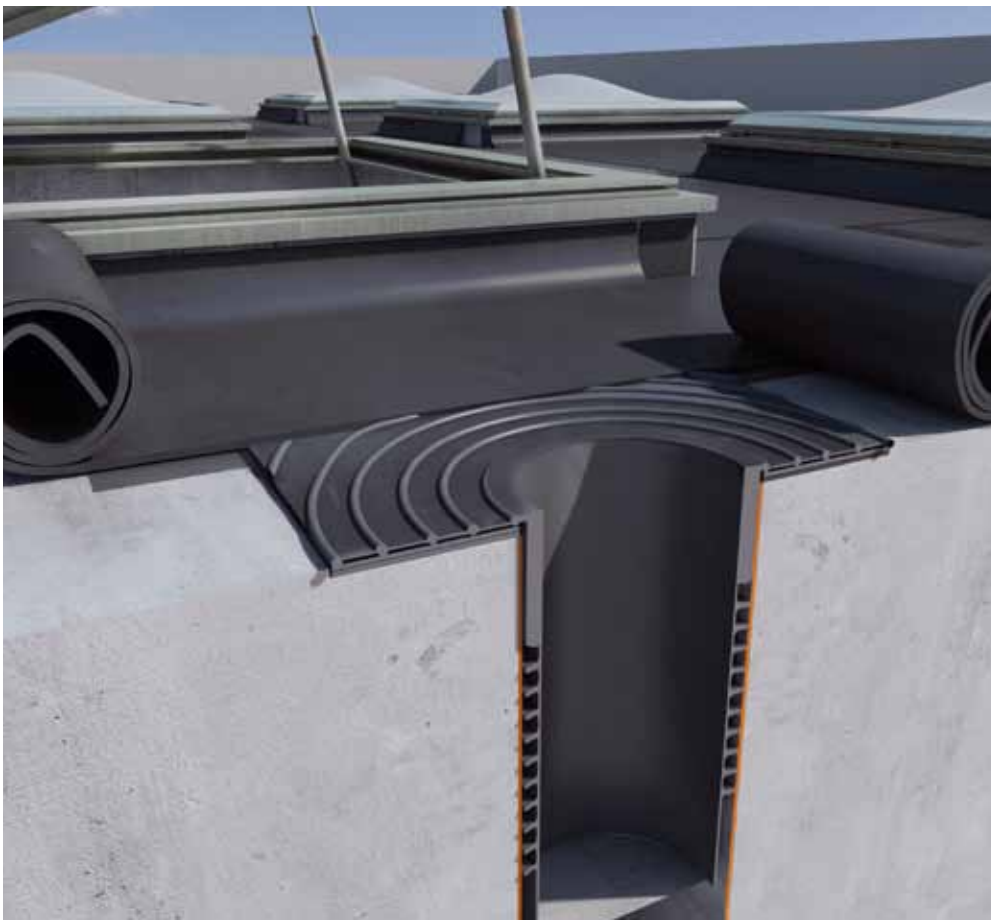
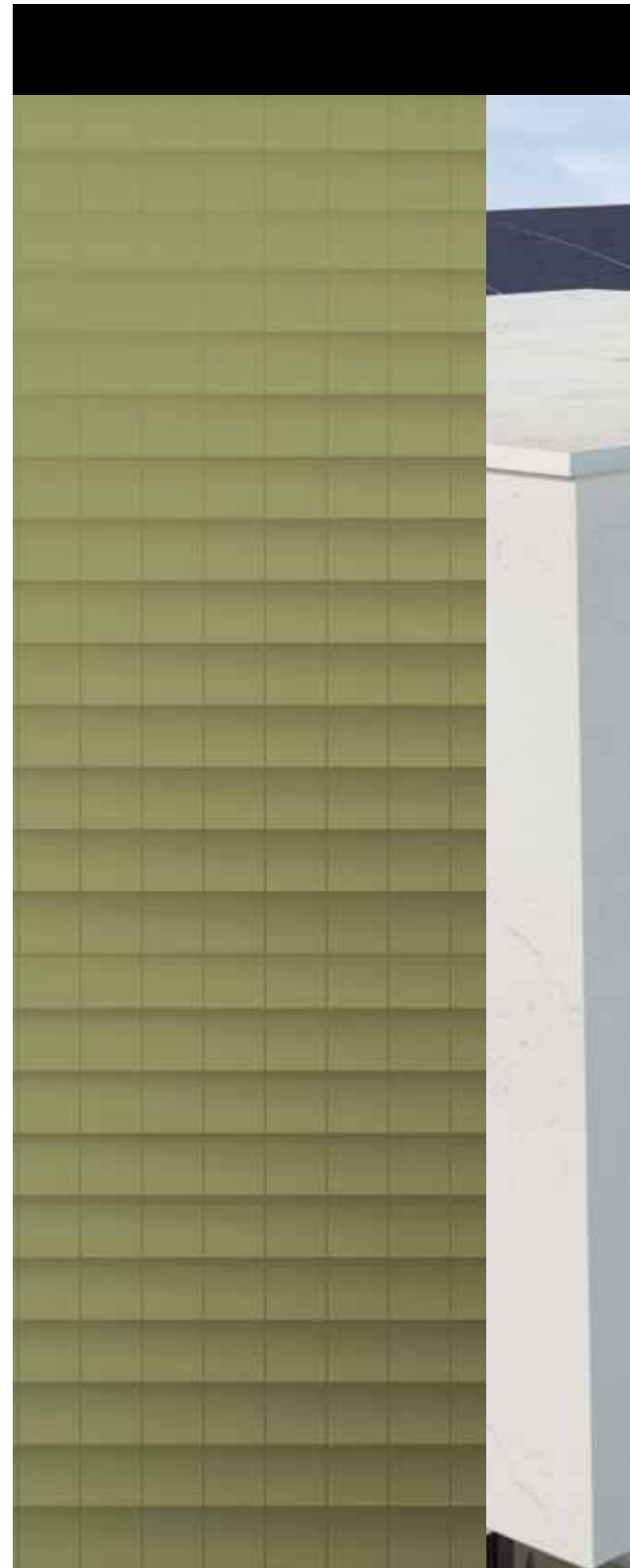
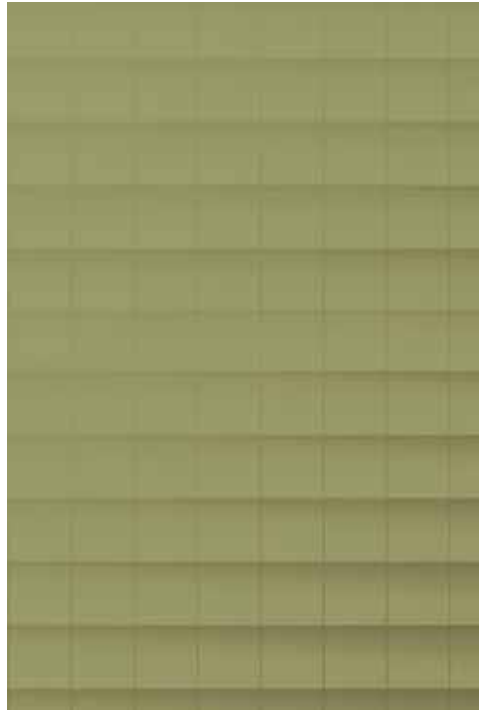

Eterno Ivica dispone di una linea completa di accessori interamente costruiti in guaina bituminosa con armatura stabilizzata. Ecco quindi i bocchettoni, gli angolari, fino al profilo angolare in bi-armato. Tutti elementi progettati, realizzati e testati dagli specialisti delle coperture impermeabilizzate in MBP. Per dare ai posatori una serie infinita di certezze.



Eterno Ivica offers a complete line of accessories made entirely from bituminous membrane with stabilized reinforcement. These include drain outlets, corner elements, and angular profiles in reinforced bituminous membrane. All the elements are designed, manufactured and tested by specialists in the field of waterproof PBM roofing. Providing installers with endless certainties.

VANTAGGI:

- Ampia gamma di misure per tubi da Ø 75 a Ø 125
- Adattabile a qualsiasi tipo di pluviale di scarico
- Alta resistenza alla fiamma
- Ampia flangia

ADVANTAGES:

- Wide range of sizes for pipes of Ø 75 to Ø 125
- Adaptable to any type of drainpipe
- Exceptional fire resistance
- Wide flange



BOCCHETTONE ETERNO "REVOLUTION" IN MBP

"REVOLUTION" ROOF DRAINS MADE OF POLYMERIC BITUMINOUS MEMBRANE



- 1** Flangia morbida e adattabile a scarichi verticali ed orizzontali
Soft flange that can be adapted to both vertical and horizontal drainpipes
- 2** Interamente stampato-termoformato, in membrana bitume-polimero armata
Totally stamped-thermoformed in reinforced polymer-bitumen membrane
- 3** Predisposizione per l'inserimento di parafoglia
Predisposed for the installation of a leaf-guard
- 4** Ampia flangia zigrinata per maggiore adesione
Large knurled flange for improved adhesion
- 5** Raccordo rinforzato da 8 strati di armatura + MBP
Reinforced connector, comprised of 8 reinforcement layers + MBP
- 6** Codolo H 250 e 450 mm
250 mm and 450 mm H shank
- 7** 10 alette antiriflusso spessore 10 mm
10 backflow flaps thickness 10 mm

VERSIONI TYPES



M B P

M B P



BOCCHETTONI "REVOLUTION" IN MEMBRANA BITUMINOSA POLIMERICA

"REVOLUTION" ROOF DRAINS MADE OF POLYMERIC BITUMINOUS MEMBRANE

Ancora una volta ETERNO IVICA rivoluziona il mondo degli accessori per le impermeabilizzazioni. La rivoluzione sta nella flangia, costituita da un fazzoletto di membrana bituminosa appositamente termoformata. La rivoluzione sta nell'adesione, assolutamente rapida e perfetta con qualsiasi membrana bituminosa, sia in mono strato sia in doppio strato. La rivoluzione sta nel codolo h 450 mm e h 250 mm, l'unico sul mercato con 10 alette veramente anti-reflusso per prevenire qualsiasi infiltrazione tra bocchettone e tubo di scarico. Visto lo spessore della membrana, si consiglia di fare attenzione al diametro effettivo di uscita del bocchettone.



Once again ETERNO IVICA does a revolution in the world of accessories for waterproofing systems. Revolution stays in the flange made of a piece of polymeric modified bituminous membrane. Revolution stays also in the adhesion, totally perfect and quick to any sort of bituminous membrane, both in single or double layer. Revolution stays ultimately in the spigot 450mm and 250 mm long, the one in the market with 10 real anti-infiltration tongues to prevent any infiltration between spigot and pipe in case of water back-up. Due to the thickness of the bituminous membrane, we please you pay attention to the real internal size of the drain.

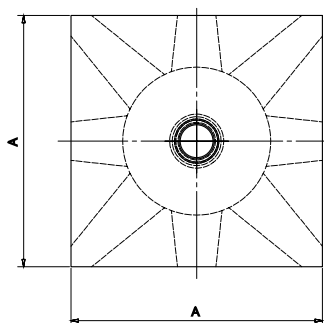
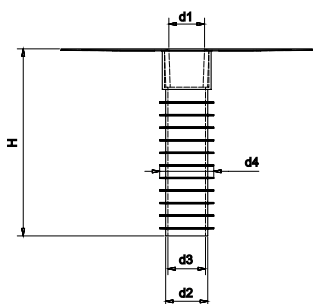

BOCCHETTONE "REVOLUTION" H 250 MM E 450 MM "REVOLUTION" ROOF DRAIN H 250 MM AND 450 MM



PRODOTTO / PRODUCT

Codice Code	Per tubi For pipes	A	D1	D2	D3	D4	H	Pagina listino Price list page	 Pz	 Pz
A310250075	Ø 75	340	52	(57)	52	75	250	4	4	64
A310250082	Ø 82	340	59	(65)	59	80	250	4	4	64
A310250090	Ø 90	340	65	(72)	65	87	250	4	4	64
A310250100	Ø 100	340	76	(83)	76	95	250	4	4	64
A310250110	Ø 110	340	85	(90)	85	110	250	4	4	64
A310250125	Ø 125	340	97	(103)	97	120	250	4	4	64
A310450075	Ø 75	340	65	(57)	52	75	450	4	4	64
A310450082	Ø 82	340	75	(65)	59	80	450	4	4	64
A310450090	Ø 90	340	80	(72)	65	87	450	4	4	64
A310450100	Ø 100	340	90	(83)	76	95	450	4	4	64
A310450110	Ø 110	340	100	(90)	85	110	450	4	4	64
A310450125	Ø 125	340	115	(103)	97	120	450	4	4	64

ANGOLI PREFABBRICATI IN MEMBRANA BITUMINOSA POLIMERICA

PREFABRICATED CORNERS MADE OF POLIMERIC BITUMINOUS MEMBRANE

M B P

M B P



Gli angoli prefabbricati bituminosi sono ottenuti dalla piegatura a caldo di un pezzo unico di membrana bituminosa con armatura composita. Il principale vantaggio è la totale fusione con la membrana bituminosa unita alla praticità e alla flessibilità di posa, offrendo maggiore garanzia di tenuta nei punti più a rischio di infiltrazione.

The bituminous prefabricated corners are made by hot folding of a unique piece of bituminous membrane with composite reinforcement. The main advantage is the total melting to the waterproofing sheet as long as their flexibility during installation which give a total waterproofing guarantee on the most risky points.

ANGOLI BITUMINOSI INTERNI INTERNAL BITUMINOUS CORNERS

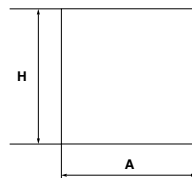

ANGOLI BITUMINOSI ESTERNI EXTERNAL BITUMINOUS CORNERS

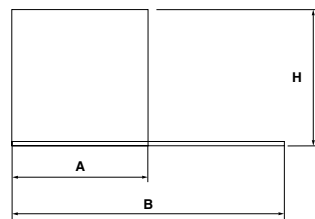

PROFILO ANGOLARE "STRIPE-BIT" "STRIPE-BIT" CANT PROFILE

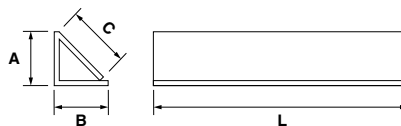

PRODOTTO / PRODUCT

Codice Code	Tipo Type	L	A	B	C	H	Pagina listino Price list page	Pz	Pz
F011004060	Angolo interno Internal corner	-	200	-	-	200	4	10	-
F010004060	Angolo esterno External corner	-	162	335	-	170	4	10	-
A300454560	Stripe-Bit	1100	45	45	60	-	5	24	-

Il profilo angolare STRIPE-BIT, come per gli angoli bituminosi, è ottenuto dalla piegatura a caldo di una membrana bituminosa con armatura composita. La sua lunghezza è di 110 cm. Like with bituminous corner profiles, the STRIPE-BIT corner profile is obtained via the hot bending of a bituminous membrane with composite reinforcement. It has a length of 110 cm.

BOCCHETTONE
"ETERNO" IN
GOMMA EPDM

"ETERNO" EPDM
RUBBER ROOF
DRAIN

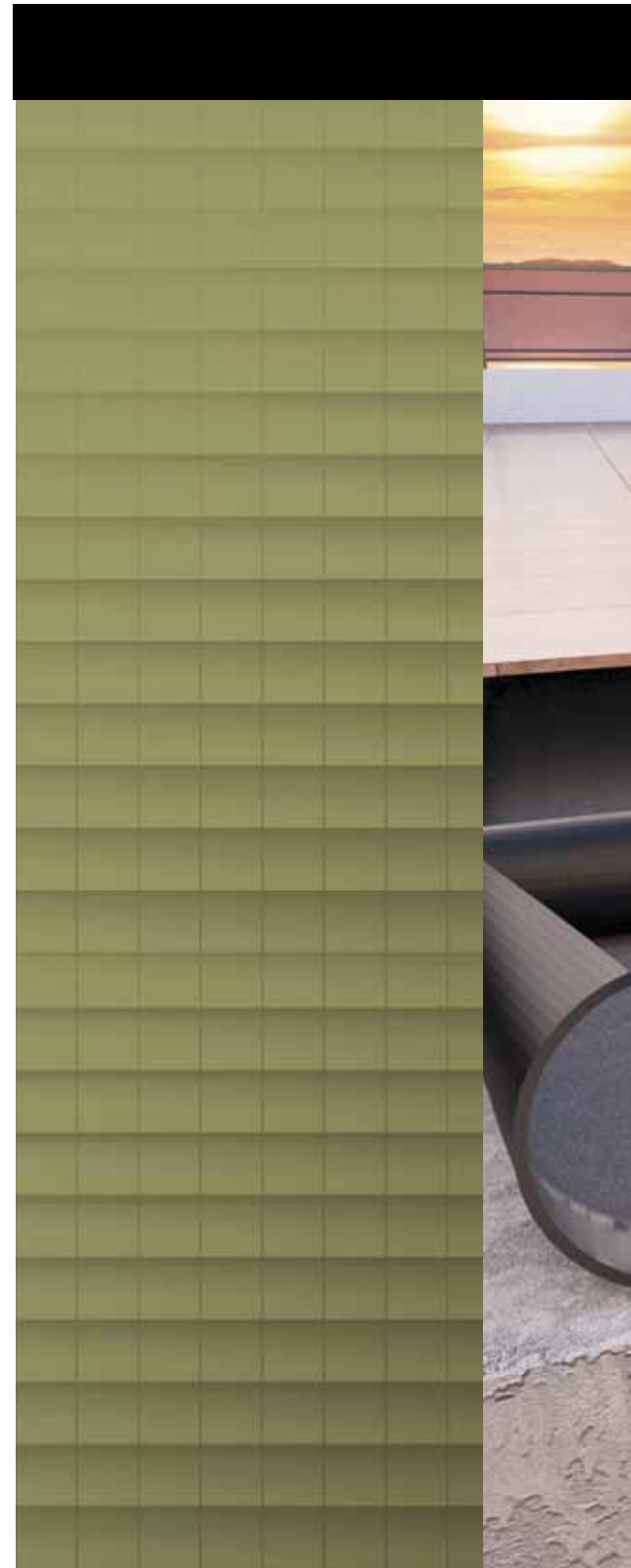
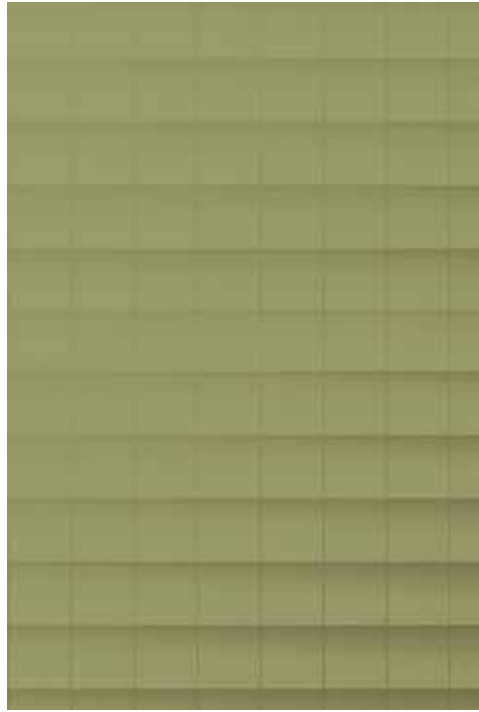

Fra gli accessori per il deflusso delle acque meteoriche proposti da Eterno Ivica troviamo la gamma di bocchettoni "Eterno" completamente realizzati in gomma EPDM, un materiale caratterizzato da un'elevata resistenza alla fiamma. I bocchettoni in gomma EPDM sono provvisti di una flangia ampia e morbida, adattabile a qualsiasi superficie, con zigrinature sulla parte inferiore. La particolare forma del codolo è studiata per aumentare l'azione "antiriflusso".

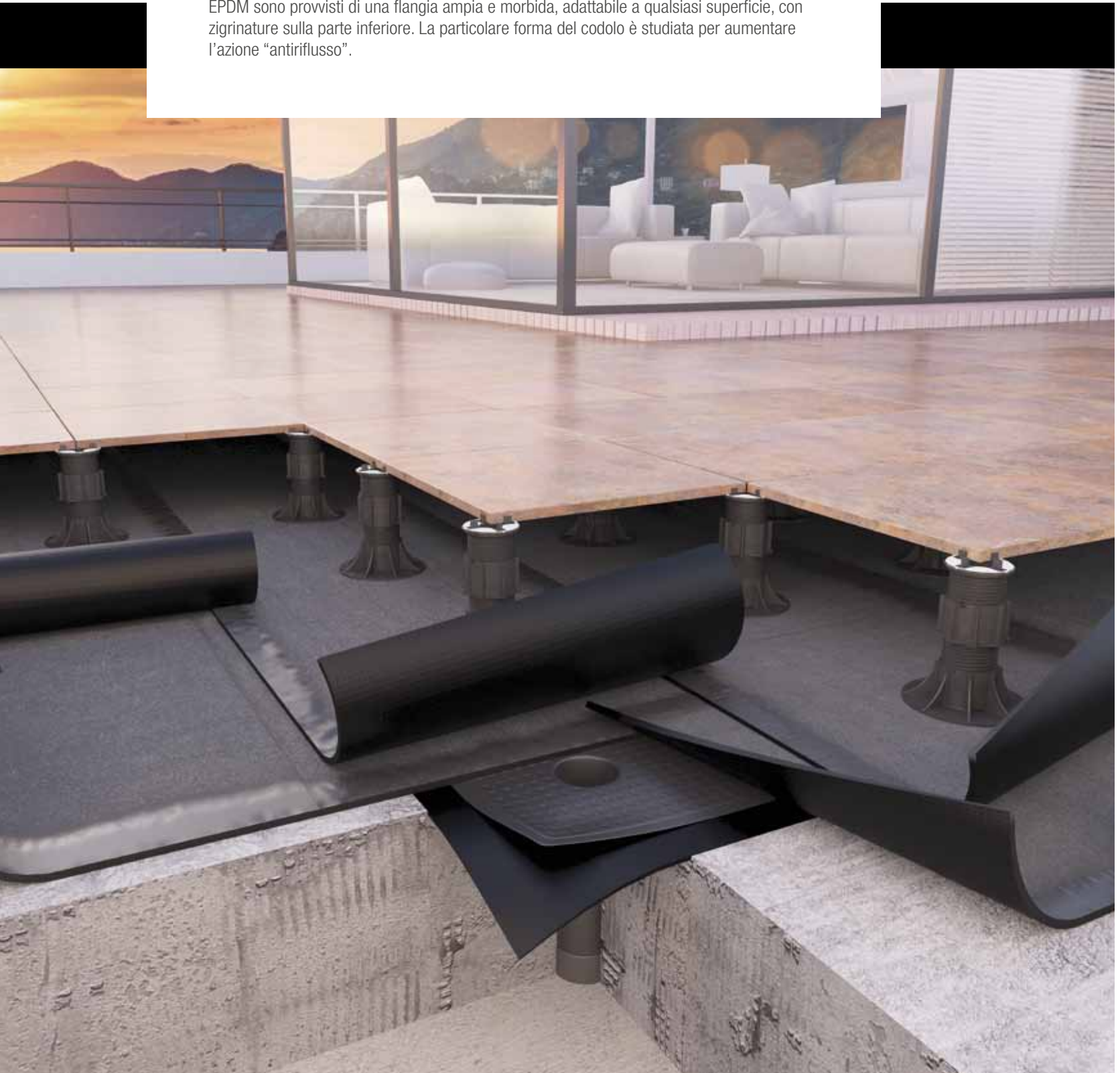

Among the accessories for rainwater drainage produced by Eterno Ivica we can find the "Eterno" drains, completely made of EPDM rubber, a material has a high resistance to flame. EPDM rubber drains are equipped with a wide and soft flange, adaptable to any surface. The particular shape of the spigot is designed to increase "anti-infiltration" effect.

VANTAGGI:

- Ampia gamma di misure per tubi da Ø 40 a Ø 200
- Adattabile a qualsiasi tipo di pluviale di scarico
- Alta resistenza alla fiamma
- Ampia flangia

ADVANTAGES:

- Wide range of sizes for pipes of Ø 40 to Ø 200
- Adaptable to any type of drainpipe
- Exceptional fire resistance
- Wide flange



BOCCHETTONE "ETERNO" IN GOMMA EPDM

"ETERNO" EPDM RUBBER ROOF DRAIN

- 1** Flangia morbida e adattabile a scarichi verticali ed orizzontali
Soft flange that can be adapted to both vertical and horizontal drainpipes
- 2** Spigolo rinforzato
Reinforced edge
- 3** Predisposizione per l'inserimento di parafoglia
Predisposed for the installation of a leaf-guard
- 4** Bassorilievi a "coda di rondine" per favorire l'aggancio del bitume fuso
"Dovetail" bas-relief to facilitate the attachment of the cast bitumen
- 5** Parte inferiore della flangia dotata di zigrinature
Knurled flange bottom
- 6** Particolare forma del codolo studiata per aumentare l'azione "antiriflusso"
Special shank form designed to favour the "backflow prevention" effect
- 7** Prolunga rigida
Rigid extension
- 8** Parte terminale della prolunga predisposta per l'inserimento di altre prolunghie
Terminal part of the extension element predisposed for the insertion of extensions
- 9** Prolunga a soffietto
Sliding extension

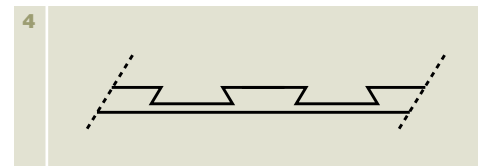

VERSIONI TYPES



GOMMA
RUBBER

MBP



BOCCHETTONE IN GOMMA EPDM CON CODOLO H 200 MM

"ETERNO" EPDM RUBBER ROOF DRAIN WITH A 200 MM SPIGOT

Interamente prodotto in gomma EPDM, è il primo, storico bocchettone di scarico inventato da ETERNO IVICA. Invariate nel tempo le intaccature a coda di rondine sulla flangia per una perfetta adesione alla membrana bituminosa ed il codolo cilindrico per una perfetta tenuta al pluviale di scarico.

Entirely manufactured in EPDM rubber, it is the very first historical roof drain invented by ETERNO IVICA. The exclusive dove-tail notches on the flange for a perfect bond to any bituminous membrane and the cylindrical spigot are still the same.

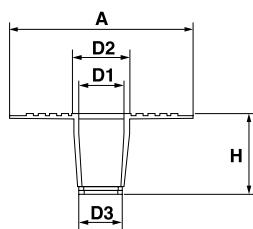
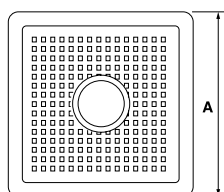

PRODOTTO / PRODUCT

Codice Code	Per tubi For pipes	A	D1	D2	D3	H	Pagina listino Price list page	Pz	
A001020040	Ø 40	250	33	39	31	175	5	25	1050
A001020050	Ø 50	310	45	50	42	200	5	25	500
A001020060	Ø 60	305	51	57	49	200	5	25	500
A001020075	Ø 75	340	66	72	63	200	5	25	400
A001020080	Ø 80	330	74	80	70	200	5	25	400
A001020090	Ø 90	330	80	86	78	200	5	25	400
A001020100	Ø 100	340	93	99	87	200	5	25	400
A001020110	Ø 110	340	99	105	94	200	5	25	400
A001020120	Ø 120	340	113	119	107	200	5	25	400
A001020125	Ø 125	370	116	122	113	200	5	20	320
A001020140	Ø 140	370	132	138	124	200	5	20	320
A001020150	Ø 150	390	140	146	132	200	5	15	240
A001020160	Ø 160	360	150	156	146	200	5	15	240
A001020200	Ø 200	440	189	195	179	210	5	10	80

BOCCHETTONE IN GOMMA EPDM SIFONATO

EPDM RUBBER ROOF DRAIN WITH TRAP

GOMMA
RUBBER

MBP



Interamente prodotto in gomma EPDM, corredato dal tradizionale codolo per l'innesto nel pluviale e dalla flangia per l'ancoraggio della membrana impermeabile, questo bocchettone è munito inoltre di una cupola per la sifonatura. Il bocchettone sifonato è venduto completo di cupola e parafoglia.

It consists of the traditional spigot that fits any kind of drain-pipe, the flange with the exclusive dove tail notches for a perfect bond to the membrane and a tank to collect the rain water. This roof drain is delivered with dome and leaf-guard.

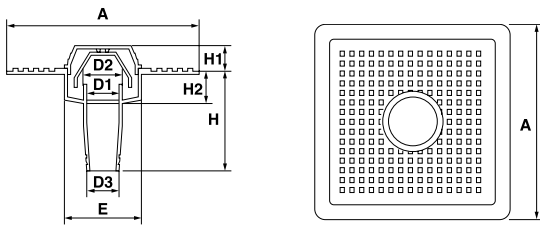

PRODOTTO / PRODUCT												
Codice Code	Tipo Type	A	D1	D2	D3	E	H	H1	H2	Pagina listino Price list page	Pz	Pz
A031000080	Ø 80	393	90	97	68	170	205	55	70	5	5	125
A031000090	Ø 90	363	93	100	78	170	205	55	70	5	5	125
A031000100	Ø 100	393	90	100	87	170	205	55	70	5	5	125
A031000110	Ø 110	363	100	107	94	170	205	55	70	5	5	125



> POSA IN OPERA
ACCESSORI PER MANTI
BITUMINOSI APP-SBS
> INSTALLATION
OF ACCESSORIES
FOR BITUMINOUS
MEMBRANES APP-SBS

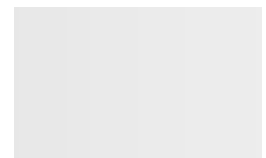

GOMMA
RUBBER

ANELLI ANTIRIFLUSSO PER BOCCHETTONI IN GOMMA EPDM H 200 MM

RETRO FIT ADAPTORS FOR EPDM ROOF DRAINS H 200 MM



Gli anelli antiriflusso sono stati sviluppati per adattare i bocchetttoni in EPDM ai tubi tipo "GEBERIT" oppure ad altre tipologie le cui misure sono espresse in pollici (inches).

The retro-fit adaptors have been specifically developed to allow the EPDM rubber roof drains to perfectly fit any kind of "GEBERIT" drain-pipes or other types of pipes whose sizes are expressed in inches.

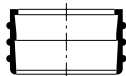

75/75

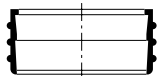

80/90

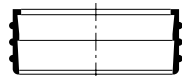

100/110

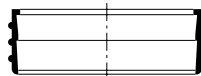

110/125



50/2 inches



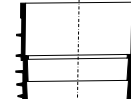

75/3 inches

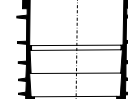

100/4 inches



110/5 inches

PRODOTTO / PRODUCT				
Codice Code	Misura Size	Pagina listino Price list page	 Pz	 Pz
F080075075	Ø 75 - 75	6	25	1750
F080080090	Ø 80 - 90	6	25	1750
F080100110	Ø 100 - 110	6	25	1750
F080110125	Ø 110 - 125	6	25	1750
F081050000	Ø 50 - 2 inches	6	25	1750
F081075000	Ø 75 - 3 inches	6	25	1750
F081100000	Ø 100 - 4 inches	6	25	1750
F081110000	Ø 110 - 5 inches	6	25	1750

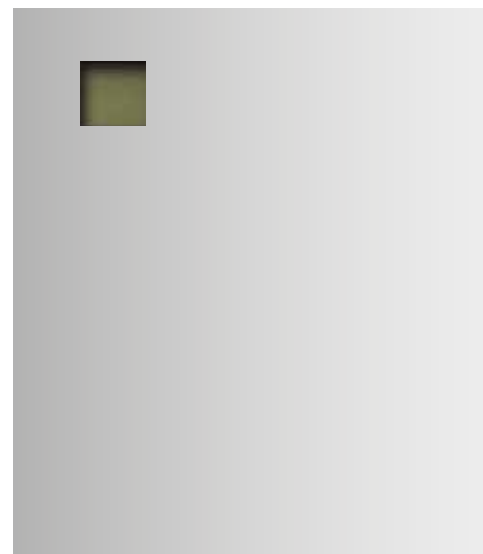

PROLUNGHE PER BOCCHETTONI IN GOMMA EPDM

EXTENSIONS FOR EPDM ROOF DRAIN

Adattabile al bocchettone in gomma EPDM H mm 200 e al bocchettone sifonato. Qualora si presenti la necessità di allungare il codolo di scarico del bocchettone, esistono delle intaccature per l'applicazione di prolunghe in gomma EPDM rigide o a soffietto.

These rubber extensions are suitable to "Eterno" roof drains made of EPDM rubber with a 200 mm spigot and to roof drains with trap only. If there should be any need to make the spigot longer, this range of rigid and flexible extensions is available.

PROLUNGA IN GOMMA EPDM EPDM RUBBER EXTENSION

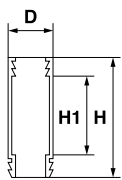

PROLUNGA A SOFFIETTO IN GOMMA EPDM EPDM RUBBER FLEXIBLE EXTENSION

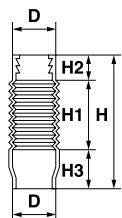

PRODOTTO / PRODUCT

Codice Code	Ø	D	H	H1	Pagina listino Price list page	Pz	Pz
B002020060	60	50	230	165	6	25	1750
B002020075	75	65	228	150	6	25	1350
B002020080	80	73	225	155	6	25	1050
B002020090	90	85	192	125	6	25	1050
B002020100	100	85	225	170	6	25	625
B002020110	110	95	230	170	6	25	625
B002020120	120	110	227	155	6	25	400
B002020125	125	115	245	165	6	20	320
B002020140	140	130	230	150	6	20	320
B002020150	150	140	240	155	6	15	240
B002020160	160	150	227	145	6	15	240
B002020200	200	190	237	150	6	10	160

PRODOTTO / PRODUCT

Codice Code	Ø	D	H	H1	H2	H3	Pagina listino Price list page	Pz	Pz
B001020075	Ø 75	70	280	145	45	90	6	25	500
B001020080	Ø 80	75	280	145	45	90	6	25	500
B001020100	Ø 100	90	280	145	45	90	6	25	400
B001020120	Ø 120	110	280	155	40	85	6	25	400
B001020125	Ø 125	115	280	170	35	85	6	20	320

GOMMA
RUBBERBOCCHETTONE IN
GOMMA EPDM



M B P

EPDM RUBBER
ROOF DRAIN

Questa particolare tipologia di bocchettone in EPDM è provvista di un codolo lungo 500 mm rinforzato sul fondo da un anello interno in plastica rigida. Proprio la lunghezza del codolo lo rende particolarmente adatto ad una applicazione su tetti industriali.

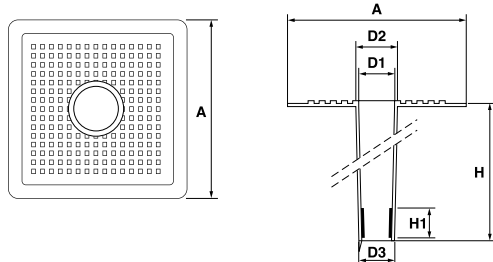
This particular type of EPDM roof drain has a 500 mm long spigot which is internally reinforced, at the bottom, with a rigid plastic ring. Thanks to the length of its spigot, it is specifically suitable for an installation on industrial roofs.

BOCCHETTONE IN GOMMA EPDM CON CODOLO H 500 MM
EPDM RUBBER ROOF DRAIN WITH A 500 MM SPIGOT

PRODOTTO / PRODUCT										
Codice Code	Per tubi For pipes	A	D1	D2	D3	H	H1	Pagina listino Price list page	 Pz	 Pz
A021050080	Ø 80	320	80	88	500	60	12	7	12	192
A021050100	Ø 100	350	100	106	500	60	12	7	12	192
A021050120	Ø 120	370	127	133	500	60	12	7	12	96
A021050150	Ø 150	385	150	156	500	60	12	7	12	96

UNA SERIE DI BOCCHETTONI DI SCARICO IN GOMMA EPDM SVILUPPATI SU APPOSITA RICHIESTA PER APPLICAZIONI SPECIALI

A RANGE OF EPDM RUBBER ROOF DRAINS SPECIFICALLY DEVELOPED ON REQUEST FOR SPECIAL APPLICATION

GOMMA RUBBER

MBP



BOCCHETTONE IN GOMMA EPDM Ø 60 MM CON CODOLO H 650 MM
EPDM RUBBER ROOF DRAIN Ø 60 MM WITH H 650 MM SPIGOT

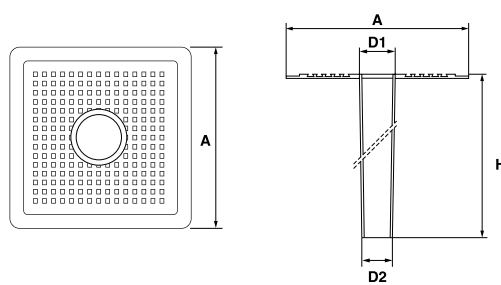

PRODOTTO / PRODUCT										
Codice Code	Per tubi For pipes	A	D1	D2	D3	H	H1	Pagina listino Price list page	Pz	Pz
A100065060	Ø 63 - 75	310	62	59	-	650	-	7	20	160

BOCCHETTONE IN GOMMA EPDM Ø 140 MM CON CODOLO H 600 MM A SOFFIETTO
EPDM RUBBER ROOF DRAIN Ø 140 MM WITH A 600 MM FLEXIBLE SPIGOT

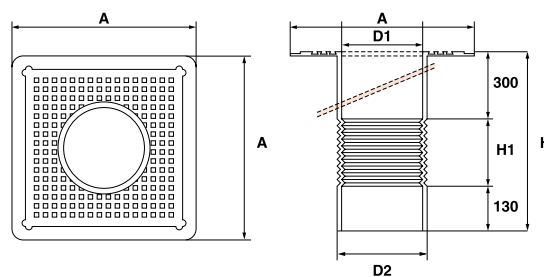

PRODOTTO / PRODUCT										
Codice Code	Per tubi For pipes	A	D1	D2	D3	H	H1	Pagina listino Price list page	Pz	Pz
A110065140	Ø 140	400	140	140	-	600	130	7	1	-

VANTAGGI:

- Adattabile a qualsiasi tipo di pluviale di scarico
- Ampia gamma di misure per tubi da Ø 63 a Ø 160
- Alta resistenza alla fiamma
- Ampia flangia

ADVANTAGES:

- Adaptable to any type of drainpipe
- Wide range of sizes for pipes of Ø 63 to Ø 160
- Exceptional fire resistance
- Wide flange

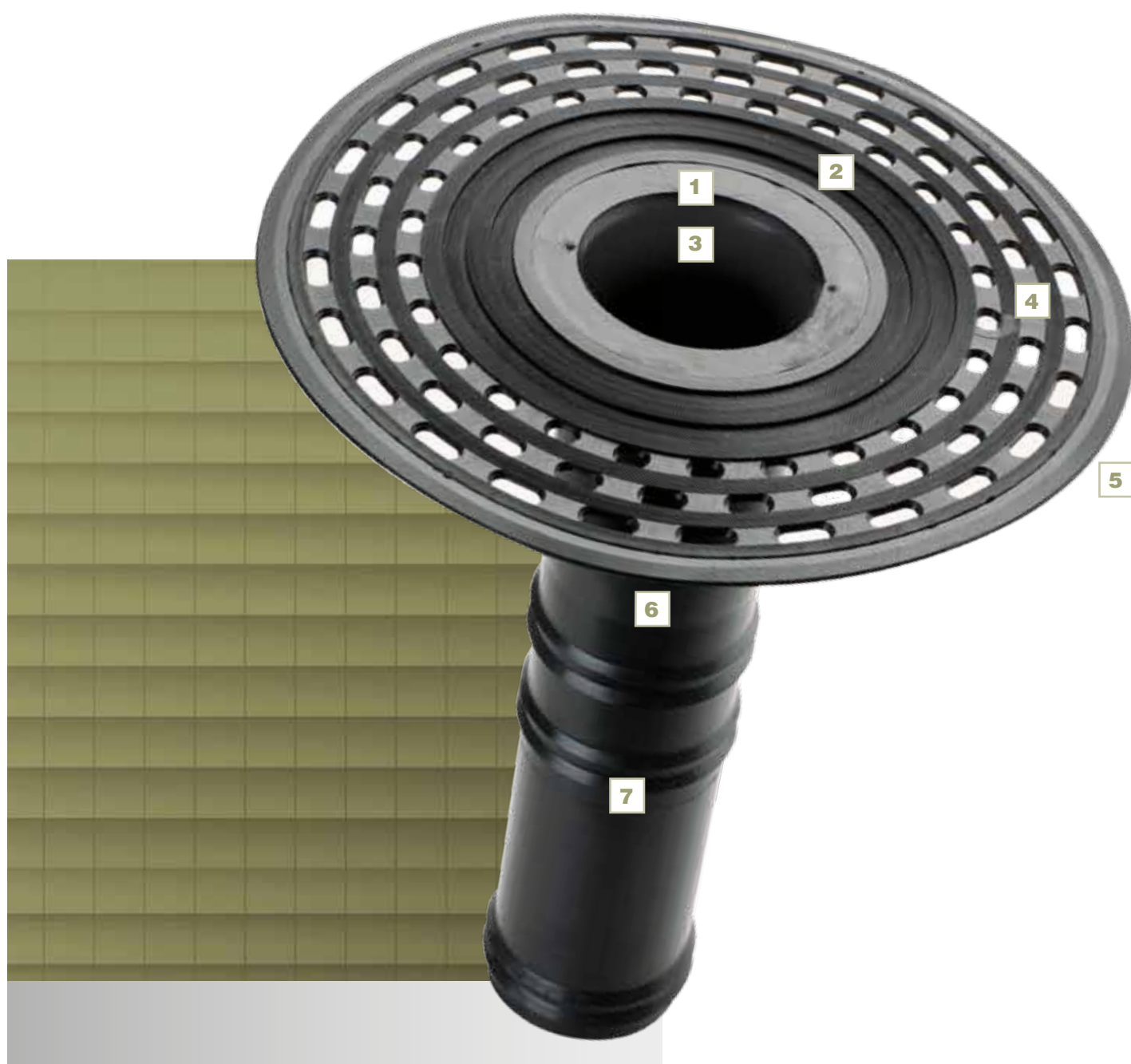

BOCCHETTONE "GENIUS" IN TPE

ROOF DRAIN "GENIUS" MADE OF TPE

- 1** Spigolo rinforzato
Reinforced edge
- 2** Anelli circolari "a coda di rondine" per favorire l'aggancio del bitume fuso
"Dovetail" circular rings to facilitate the attachment of the cast bitumen
- 3** Predisposizione per l'inserimento di parafoglia
Predisposed for the installation of a leaf-guard
- 4** Fori passanti per favorire la perfetta fusione della membrana superiore con quella inferiore
Through-holes to facilitate the upper membrane's perfect fusion with the lower membrane
- 5** Parte inferiore della flangia dotata di zigrinature
Knurled flange bottom
- 6** Codolo H 250 mm e H 400 mm
250 mm H and 400 mm H spigot
- 7** Coppie di alette "antiriflusso" spessore 1 cm
Two 1cm thick "backflow prevention" flaps

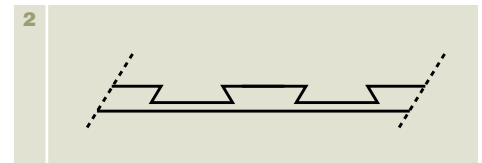

VERSIONI TYPES



TPE

MBP



BOCCHETTONE "GENIUS" IN TPE CON CODOLO H 250 MM E 400 MM

"GENIUS" ROOF DRAIN MADE OF TPE WITH A 250 MM OR 400 MM SPIGOT

Realizzato con uno speciale compound di gomma termoplastica, resistente alle basse temperature (flessibilità a freddo = -40°), è compatibile con qualsiasi membrana a base di bitume. Il bocchettone "Genius" è dotato di un esclusivo settore circolare della flangia con fori passanti, che permettono la perfetta fusione tra la membrana bituminosa posta al di sopra della flangia con quella posta al di sotto. Il codolo è dotato di due o tre coppie di alette antiriflusso. Il prodotto è BREVETTATO.

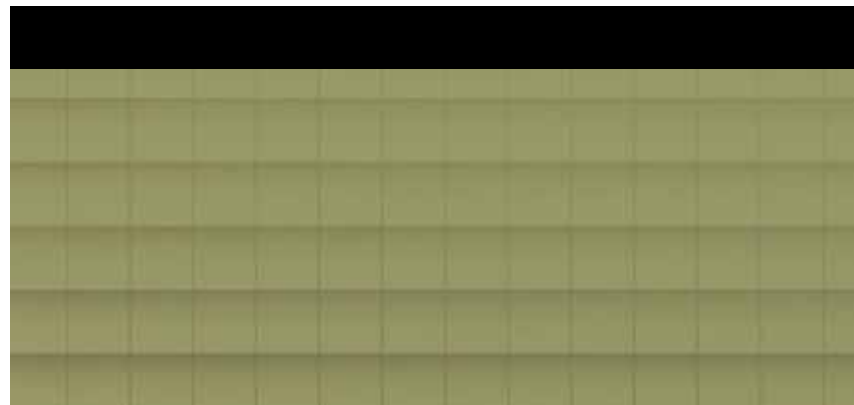

Manufactured of a special compound of thermoplastic rubber, it is highly resistant against low temperatures (cold flexibility = -40°) as well as perfectly compatible with all sorts of bituminous waterproofing membrane. "Genius" is the only roof drain in the world with a special circular row of holes and through these holes the waterproofing membrane torched over its flange is totally blended with the membrane below. The spigot is provided with two or three couples of anti-infiltration tongues that prevent any infiltration. The product is PATENTED.

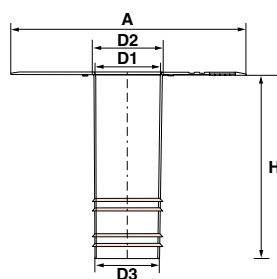
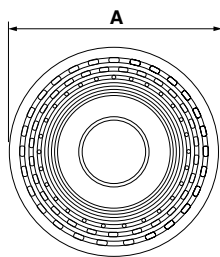

BOCCHETTONE "GENIUS" IN TPE CON CODOLO H 250 MM "GENIUS" ROOF DRAIN MADE OF TPE WITH A 250 MM





PRODOTTO / PRODUCT

Codice Code	Per tubi For pipes	A	D1	D2	D3	H	Pagina listino Price list page	 Pz	 Pz
A017025063	Ø 63	320	51	60	49	250	8	25	400
A017025075	Ø 75	320	63	70	62	250	8	25	400
A017025082	Ø 82	320	69	75	68	250	8	25	400
A017025090	Ø 90	320	80	84	79	250	8	25	400
A017025100	Ø 100	320	86	90	85	250	8	25	400
A017025110	Ø 110	380	95	101	94	250	8	15	240
A017025125	Ø 125	380	109	115	108	250	8	15	240
A017025140	Ø 140	380	128	134	127	250	8	10	160
A017025150	Ø 150	380	134	140	132	250	8	10	160
A017025160	Ø 160	380	140	146	139	250	8	10	160

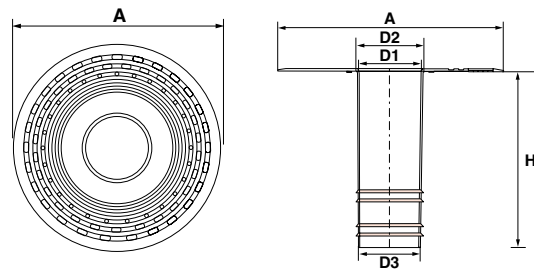
BOCCHETTONE "GENIUS"
IN TPE CON CODOLO
H 400 MM
"GENIUS" ROOF DRAIN
MADE OF TPE WITH
A 400 MM



PRODOTTO / PRODUCT

Codice Code	Per tubi For pipes	A	D1	D2	D3	H	Pagina listino Price list page	 Pz	 Pz
A017040063	Ø 63	320	51	60	49	400	8	15	240
A017040075	Ø 75	320	63	70	62	400	8	15	240
A017040082	Ø 82	320	69	75	68	400	8	15	240
A017040090	Ø 90	320	80	84	79	400	8	15	240
A017040100	Ø 100	320	86	90	85	400	8	15	240
A017040110	Ø 110	380	95	101	94	400	8	12	192
A017040125	Ø 125	380	109	115	108	400	8	12	96
A017040140	Ø 140	380	128	134	127	400	8	10	80
A017040150	Ø 150	380	134	140	132	400	8	10	80
A017040160	Ø 160	380	140	146	139	400	8	10	80

TPE

MBP



BOCCHETTONE "EURO" IN TPE CON CODOLO H 250 MM E 400 MM



"EURO" ROOF DRAIN MADE OF TPE WITH A 250 OR 400 MM SPIGOT

Realizzato con uno speciale compound di gomma termoplastica, resistente alle basse temperature (flessibilità a freddo = -40°), è compatibile con qualsiasi membrana a base di bitume. La flangia è dotata di canali a "coda di rondine" e di una speciale zigrinatura che garantiscono l'aggancio delle membrane bituminose. Il codolo è dotato di due o tre coppie di alette antiriflusso, a seconda che sia lungo 250 mm o 400 mm.

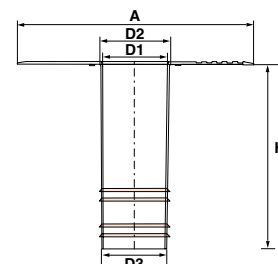
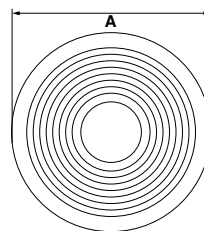

Manufactured of a special compound of thermoplastic rubber, it is highly resistant against low temperatures (cold flexibility = -40°) as well as perfectly compatible with all sorts of bituminous waterproofing membrane. The traditional dove-tail channels and special shagreens on the flange allow a perfect bond to the membrane. The spigot is provided with two or three couples of anti-infiltration tongues that prevent any infiltration between the spigot and the drain pipe.



PRODOTTO / PRODUCT

Codice Code	Per tubi For pipes	A	D1	D2	D3	H	Pagina listino Price list page	 Pz	 Pz
A013025063	Ø 63	320	51	60	49	250	9	25	400
A013025075	Ø 75	320	63	70	62	250	9	25	400
A013025082	Ø 82	320	69	75	68	250	9	25	400
A013025090	Ø 90	320	80	84	79	250	9	25	400
A013025100	Ø 100	320	86	90	85	250	9	25	400
A013025110	Ø 110	380	95	101	94	250	9	15	240
A013025125	Ø 125	380	109	115	108	250	9	15	240
A013025140	Ø 140	380	128	134	127	250	9	10	160
A013025150	Ø 150	380	134	140	132	250	9	10	160
A013025160	Ø 160	380	140	146	139	250	9	10	160

PRODOTTO / PRODUCT

Codice Code	Per tubi For pipes	A	D1	D2	D3	H	Pagina listino Price list page	 Pz	 Pz
A013040063	Ø 63	320	51	60	49	400	9	15	240
A013040075	Ø 75	320	63	70	62	400	9	15	240
A013040082	Ø 82	320	69	75	68	400	9	15	240
A013040090	Ø 90	320	80	84	79	400	9	15	240
A013040100	Ø 100	320	86	90	85	400	9	15	240
A013040110	Ø 110	380	95	101	94	400	9	12	192
A013040125	Ø 125	380	109	115	108	400	9	12	96
A013040140	Ø 140	380	128	134	127	400	9	10	80
A013040150	Ø 150	380	134	140	132	400	9	10	80
A013040160	Ø 160	380	140	146	139	400	9	10	80

BOCCHETTONE "MONDIAL" IN TPE CON CODOLO H 170 MM E 250 MM



"MONDIAL" ROOF DRAIN MADE OF TPE
WITH A 170 OR 250 MM SPIGOT



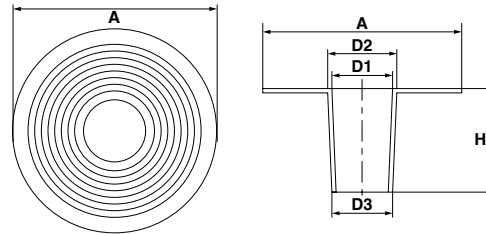

Realizzato con uno speciale compound di gomma termoplastica, resistente alle basse temperature (flessibilità a freddo = -40°), è compatibile con qualsiasi membrana a base di bitume. La flangia è dotata di canali a "coda di rondine" e di una speciale zigrinatura che garantiscono l'aggancio delle membrane bituminose.

Manufactured of a special compound of thermoplastic rubber, it is highly resistant against low temperatures (cold flexibility = -40°) as well as perfectly compatible with all sorts of bituminous waterproofing membrane. The traditional dove-tail channels and special shagreens on the flange allow a perfect bond to the membrane making the seal 100% effective.



PRODOTTO / PRODUCT									
Codice Code	Per tubi For pipes	A	D1	D2	D3	H	Pagina listino Price list page		
A010017060	Ø 60	265	52	56	49	170	10	25	625
A010017080	Ø 80	305	74	78	74	170	10	25	500
A010017100	Ø 100	335	93	97	89	170	10	25	400
A010017120	Ø 120	335	108	112	108	170	10	25	400
A010017150	Ø 150	365	137	141	137	170	10	10	200

PRODOTTO / PRODUCT									
Codice Code	Per tubi For pipes	A	D1	D2	D3	H	Pagina listino Price list page		
A012025060	Ø 60	265	52	56	49	250	10	25	400
A012025080	Ø 80	305	74	78	74	250	10	25	400
A012025100	Ø 100	335	93	97	89	250	10	25	400
A012025120	Ø 120	335	108	112	108	250	10	15	240
A012025150	Ø 150	365	137	141	137	250	10	10	160

BOCCHETTONE
CON SCARICO
VERTICALE O
LATERALE IN TPE

TPE ROOF DRAIN
WITH SIDE OR
VERTICAL EXIT

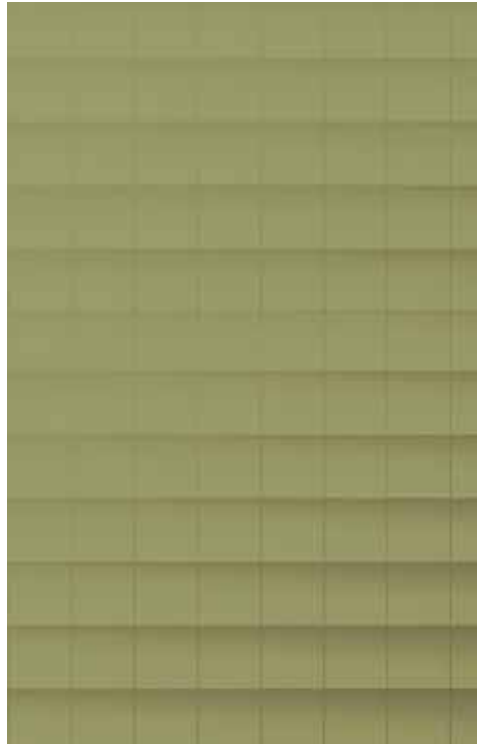

Il bocchettone in TPE, disponibile con scarico verticale o laterale, è realizzato con uno speciale compound di gomma termoplastica resistente alle basse temperature e compatibile con qualsiasi membrana a base di bitume. Il bocchettone in TPE è dotato di un esclusivo settore circolare della flangia con fori passanti, che permettono la perfetta fusione tra la membrana bituminosa posta al di sopra della flangia con quella che si trova al di sotto. Il prodotto è BREVETTATO.

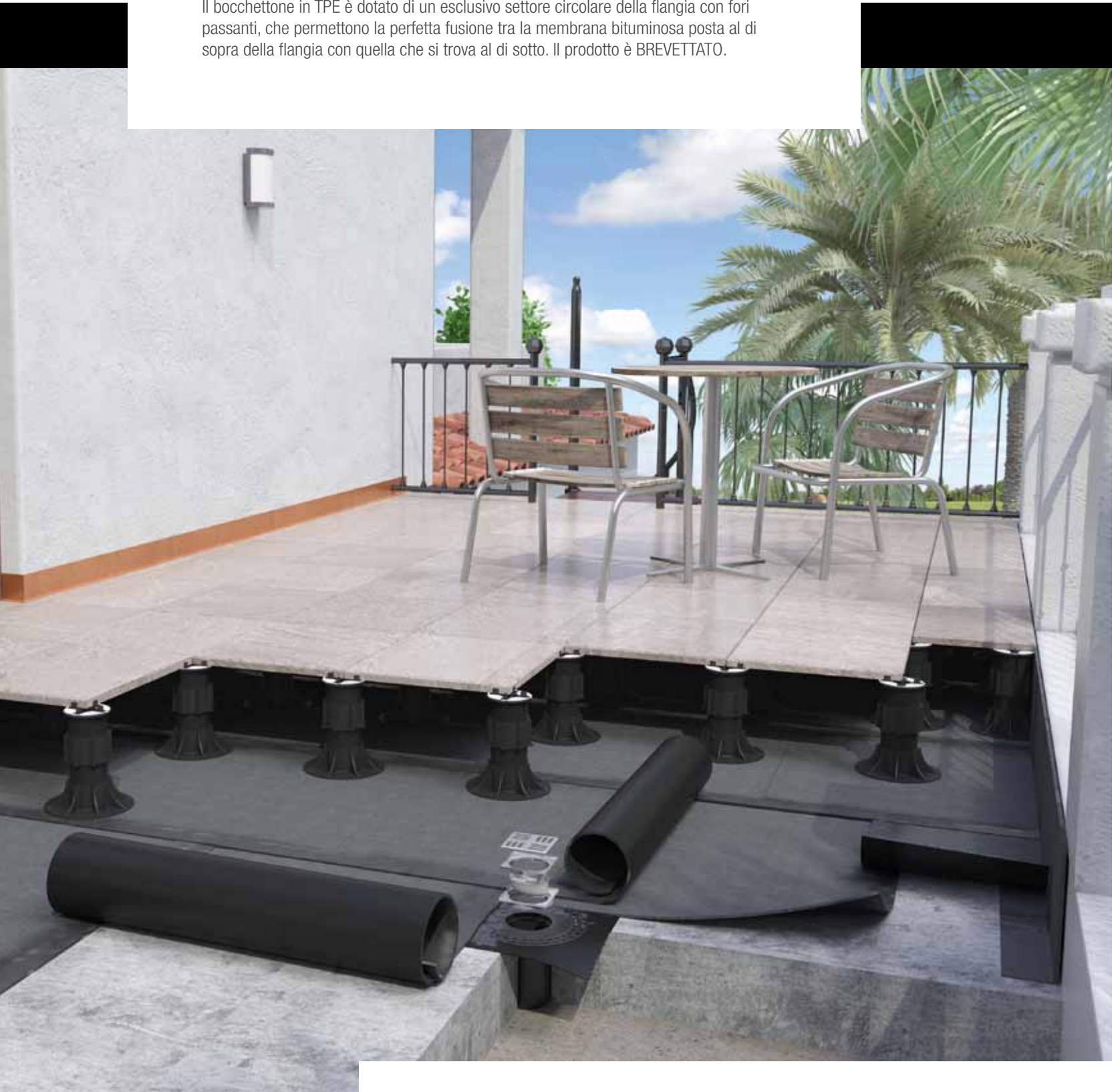

TPE roof drain, available with vertical or lateral exit, is made of a special compound of TPR resistant to low temperatures and compatible with any bitumen membrane. TPE roof drain is equipped with an exclusive flange with holes, which allow the perfect fusion between the bitumen membrane placed above the flange with the one located below. The product is PATENTED.

VANTAGGI:

- Adattabile a qualsiasi tipo di pluviale di scarico
- Ampia gamma di misure per tubi da Ø 50 a Ø 100
- Alta resistenza alla fiamma

ADVANTAGES:

- Adaptable to any type of drainpipe
- Wide range of sizes for pipes of Ø 50 to Ø 100
- Exceptional fire resistance

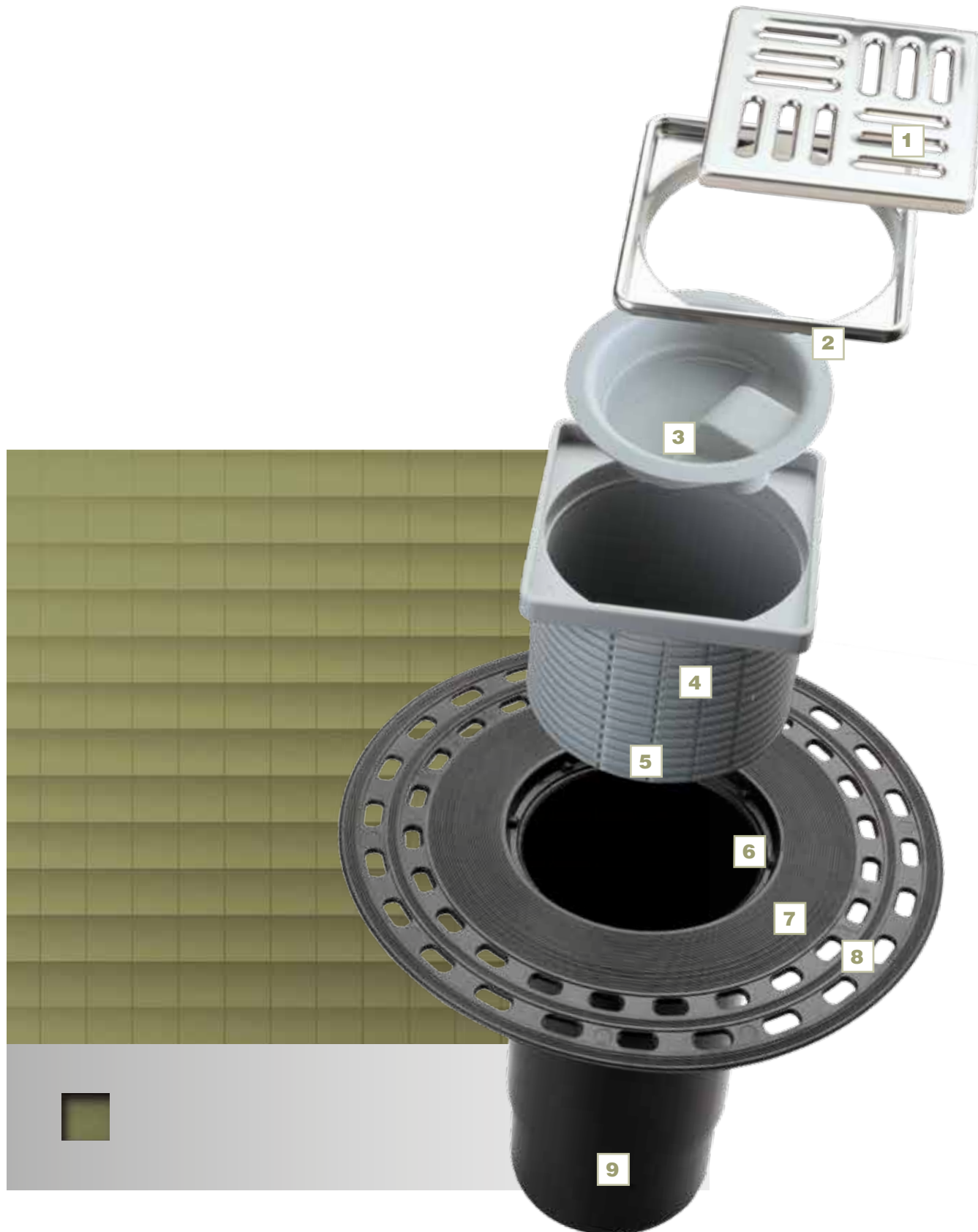

BOCCHETTONE CON SCARICO VERTICALE O LATERALE IN TPE

TPE ROOF DRAIN WITH SIDE OR VERTICAL EXIT

- 1** Griglia in acciaio inox
Stainless steel grate
- 2** Telaio in acciaio inox
Stainless steel frame
- 3** Valvola anti-intrusione Ø 50 / 75 / 82 / 90 / 100 *
Anti-intrusion cap Ø 50 / 75 / 82 / 90 / 100 *
- 4** Prolunga
Extension element
- 5** Scanalatura per il deflusso dell'acqua
Water drainage groove
- 6** Scanalatura interna "acqua non stop"
"Non-stop water" internal groove
- 7** Parte inferiore e superiore della flangia zigrinata
Top and bottom part of the knurled flange
- 8** Flangia forata per una perfetta saldatura su qualsiasi sistema
impermeabilizzante bituminoso
Flange perfectly compatible with any bituminous or resin waterproofing
- 9** Bocchettone verticale Ø 50 / 75 / 82 / 90 / 100
Roof drain vertical Ø 50 / 75 / 82 / 90 / 100

* La valvola anti-intrusione dello scarico orizzontale è sempre Ø 100

* Anti-intrusion cap on side drain is always Ø 100

BOCCHETTONE LATERALE Ø 50 / 75 / 90 ROOF DRAIN SIDE Ø 50 / 75 / 90

- 1** Bocchettone orizzontale Ø 50 / 75 / 90
Roof drain side Ø 50 / 75 / 90
- 2** Fondo inclinato anti-ristagno d'acqua
Sloping bottom to prevent water stagnation



TPE

MBP



BOCCHETTONE CON SCARICO LATERALE O VERTICALE IN TPE

TPE ROOF DRAIN WITH SIDE OR VERTICAL EXIT





I bocchettoni in TPE sono la soluzione ideale per balconi e terrazze: la flangia forata permette la perfetta saldatura su qualsiasi sistema impermeabilizzante bituminoso o resinoso. Il sistema è integrato da una prolunga con griglia e telaio in acciaio inox, la cui altezza può essere facilmente modificata in base allo spessore del massetto, e da una speciale valvola anti-intrusione "senz'acqua". Gli elementi sono da ordinarsi separatamente.

The TPE roof drain with side and vertical exit is the ideal solution for balconies and terraces: its flange with holes is perfectly compatible with any bituminous or resin waterproofing. System is composed by an extension element that can be adjusted according to concrete screed thickness, and by a stainless steel grate plus frame. A special anti-intrusion cap is also available on request. Elements to be ordered separately.

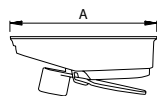

VALVOLA ANTI-INTRUSIONE ANTI-INTRUSION CAP



PRODOTTO / PRODUCT									
Codice Code	Per tubi For pipes	Valvola anti-intrusione Anti-intrusion cap	A	A1	H	D	Pagina listino Price list page	 Pz	 Pz
A410010050	Ø 50	Ø 50	42,3	-	-	-	11	1	-
A410010075	Ø 75	Ø 75	66,0	-	-	-	11	1	-
A410010082	Ø 82	Ø 82	71,8	-	-	-	11	1	-
A410010090	Ø 90	Ø 90	80,5	-	-	-	11	1	-
A410010100	Ø 100	Ø 100	89,8	-	-	-	11	1	-

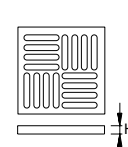
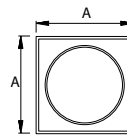
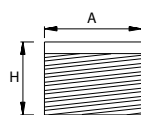

PROLUNGA E GRIGLIA EXTENSION AND GRATING



PRODOTTO / PRODUCT						
Codice Code	Per tubi For pipes	A	H	Pagina listino Price list page	 Pz	 Pz
A420100078	Prolunga H 90 / Extension element H 90	99	88	11	1	-
A420100037	Prolunga H 50 / Extension Element H 50	99	48	11	1	-
A420100018	Prolunga H 18 / Extension Element H 18	99	17,5	11	1	-
A430100100	Griglia con telaio / Grating with frame	104	5	11	1	-

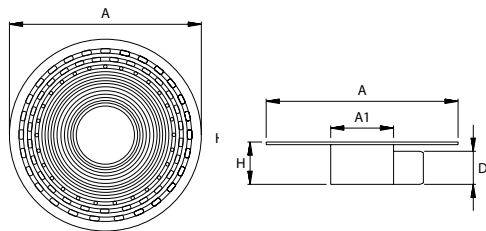

BOCCHETTONE LATERALE
ROOF DRAIN SIDE

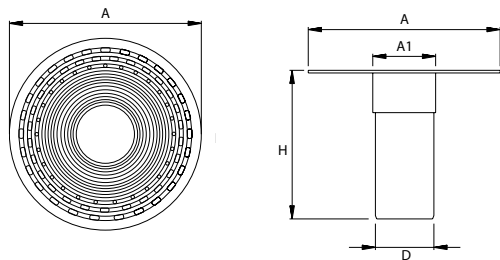

PRODOTTO / PRODUCT									
Codice Code	Per tubi For pipes	Valvola anti-intrusione Anti-intrusion cap	A	A1	H	D	Pagina listino Price list page		
A201001050	Ø 50	Ø 100	230	89,9	70	49,5	11	18	-
A201001070	Ø 75	Ø 100	230	89,9	90	73,1	11	18	-
A201001090	Ø 90	Ø 100	230	89,9	120	88,6	11	18	-

BOCCHETTONE VERTICALE
ROOF DRAIN VERTICAL



PRODOTTO / PRODUCT									
Codice Code	Per tubi For pipes	Valvola anti-intrusione Anti-intrusion cap	A	A1	H	D	Pagina listino Price list page		
A201002050	Ø 50	Ø 50	230	42,3	200	42,3	11	9	-
A201002075	Ø 75	Ø 75	230	66	200	70,3	11	9	-
A201002082	Ø 82	Ø 82	230	71,8	200	76,1	11	9	-
A201002090	Ø 90	Ø 90	230	80,5	200	84,8	11	9	-
A201002100	Ø 100	Ø 100	230	89,8	200	94,1	11	9	-

BOCCHETTONI
ANGOLARI IN TPE
PER POGGIOLI

TPE ANGULAR
DRAINS FOR
BALCONIES

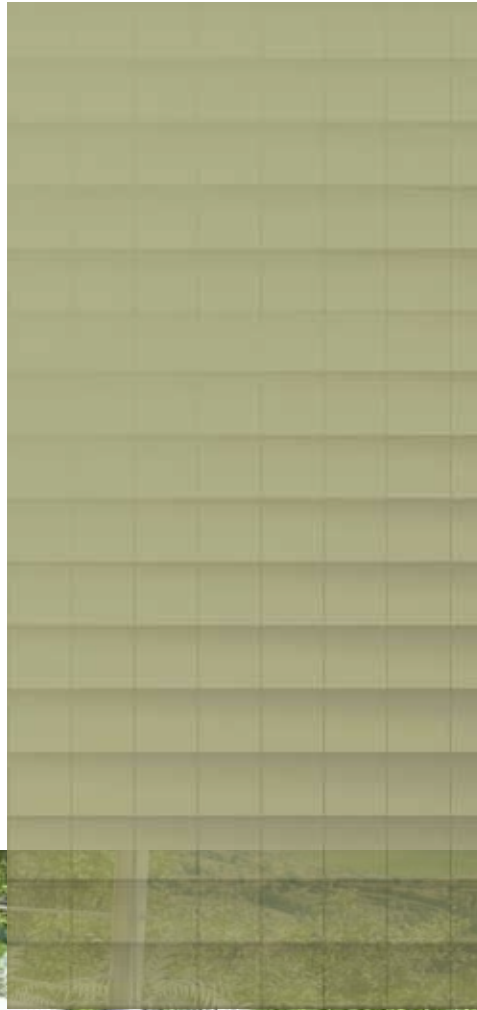

I Bocchettoni angolari per poggiali in TPE, utilizzabili in qualsiasi condizione climatica, garantiscono una eccellente resistenza alla fiamma e alle basse temperature (-40°C). Queste caratteristiche, unite alla semplicità della posa in opera, rendono questi articoli economici pur mantenendo standard qualitativi molto alti. Caratterizzati da un'ampia flangia e disponibili in diverse sezioni e lunghezze di codolo, rappresentano un dettaglio fondamentale per la corretta canalizzazione e deflusso delle acque meteoriche su terrazze e balconi, assicurando una saldatura perfetta su qualsiasi sistema impermeabilizzante bituminoso o resinoso.

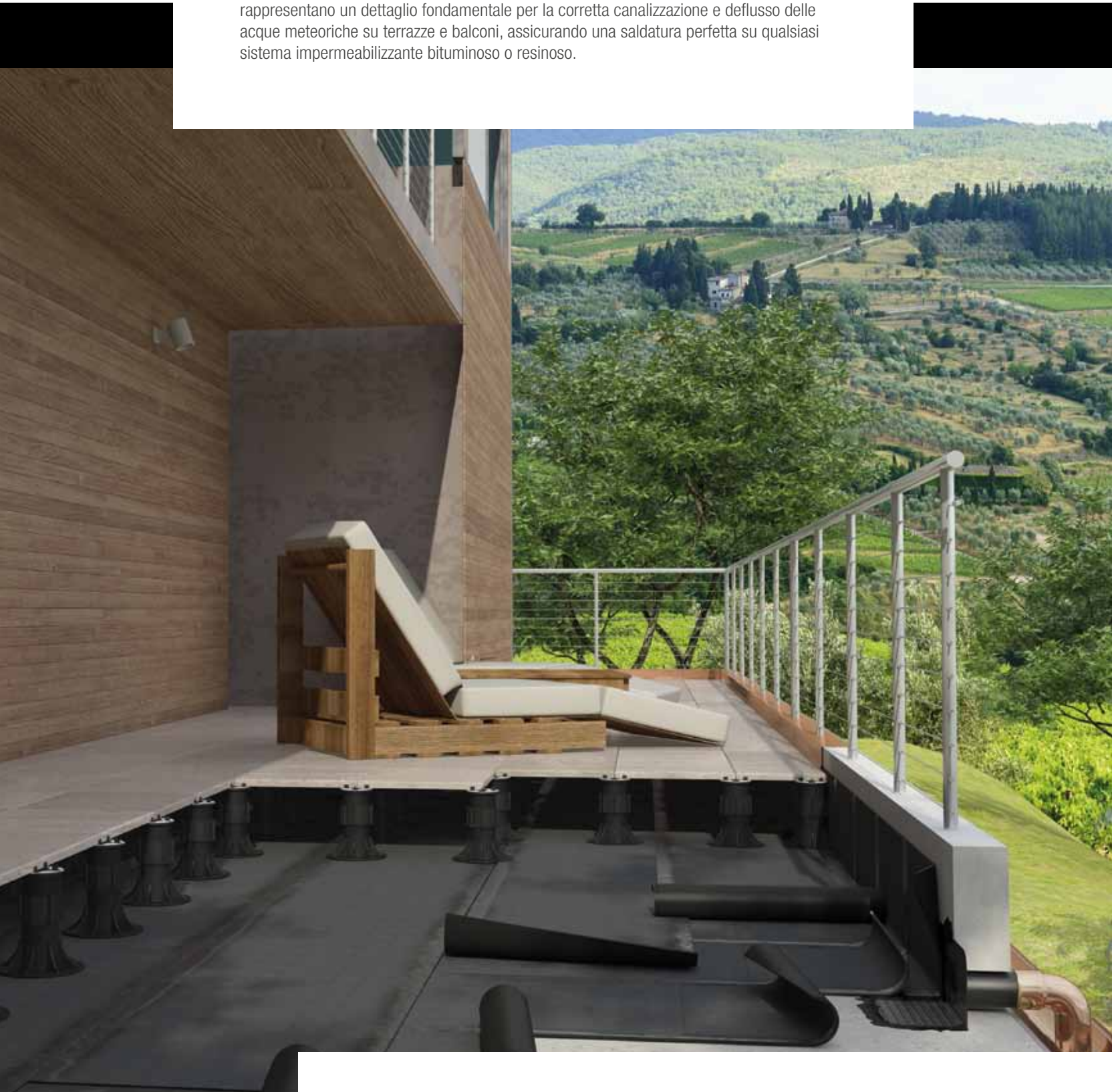

Angular TPE roof drains are usable in any climate and they provide both excellent fire and low temperature resistance (-40° C). These features, combined with the simplicity of installation, make these items an economic solution while maintaining very high standards. Characterized by a wide flange and available in different sections and lengths of exit, they represent a crucial detail for the correct water drainage on terraces and balconies, ensuring perfect welding on any bituminous waterproofing system.

VANTAGGI:

- Alta resistenza alla fiamma
- Ampia flangia
- Disponibile in diverse sezioni e lunghezze codolo

ADVANTAGES:

- Exceptional fire resistance
- Wide flange
- Available in various cross-sections and shank lengths

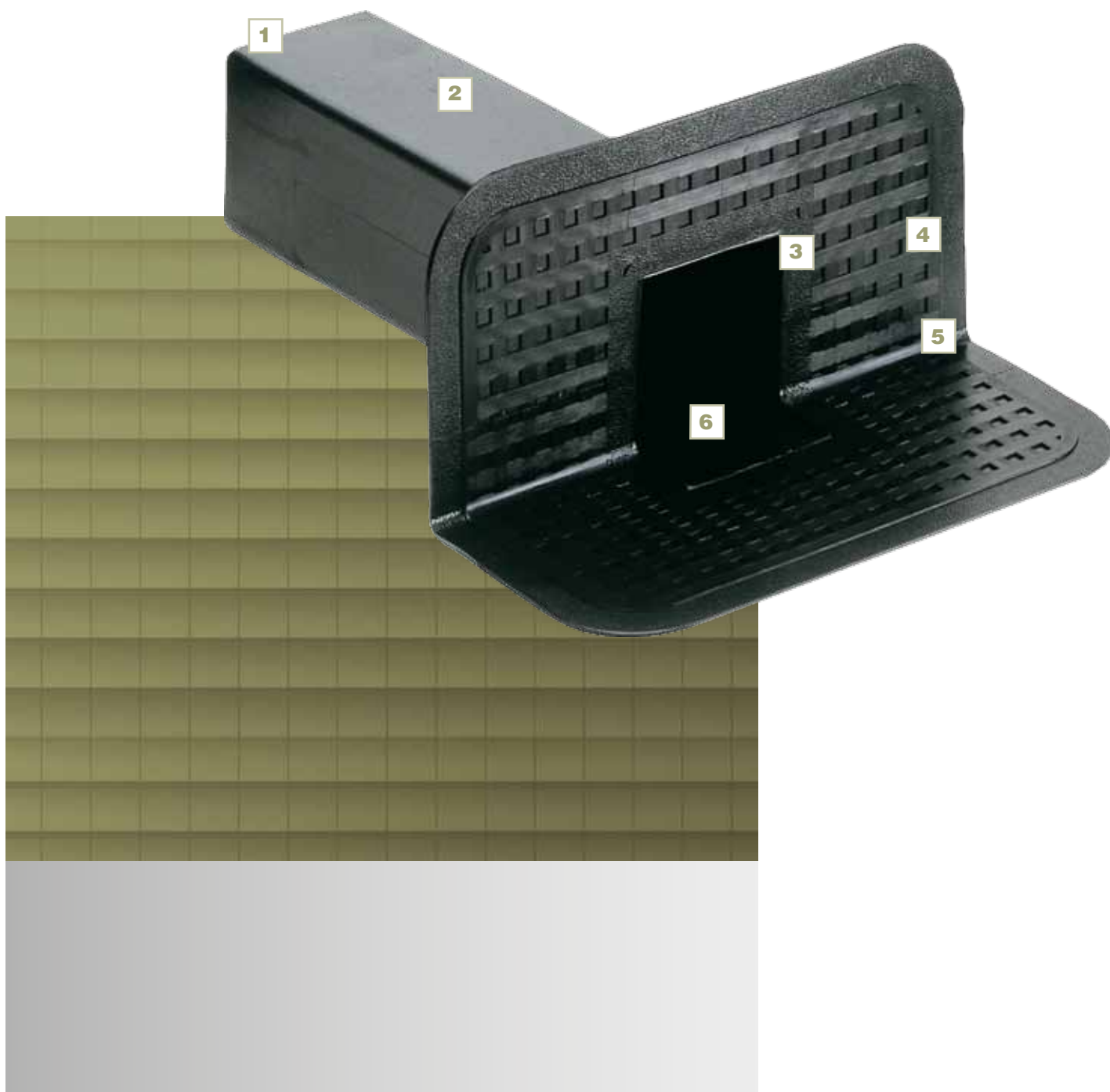

BOCCHETTONE ANGOLARE IN TPE

TPE ANGULAR DRAINS

- 1** Predisposizione per l'inserimento di "raccordo"
Predisposed for the insertion of a "connector"
- 2** Lunghezza codolo da 370 mm a 500 mm
Shank length from 370 mm to 500 mm
- 3** Spigolo rinforzato
Reinforced edge
- 4** Bassorilievi "a coda di rondine" per favorire l'aggancio del bitume fuso
"Dovetail" bas-relief to facilitate the attachment of the cast bitumen
- 5** Angolo a 90° raggaiato
Radiused 90° corner element
- 6** Predisposizione per l'inserimento di parafoglia
Predisposed for the installation of a leaf-guard

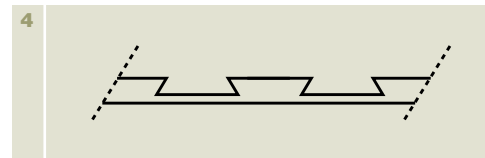

VERSIONI TYPES



BOCCHETTONE ANGOLARE ANGOLO 90°
SEZIONE TONDA DA Ø 63 mm a Ø 125 mm
ANGULAR DRAIN 90° with ROUND SPIGOT
from Ø 63 mm to Ø 125 mm



BOCCHETTONE ANGOLARE ANGOLO 90°
per POGGIOLI SEZIONE 57 x 78 mm
ANGULAR DRAIN 90° for BALCONIES 57 x 78 mm SECTION



BOCCHETTONE ANGOLARE ANGOLO 90°
per POGGIOLI SEZIONE 57 x 48 mm
ANGULAR DRAIN 90° for BALCONIES 57 x 48 mm SECTION

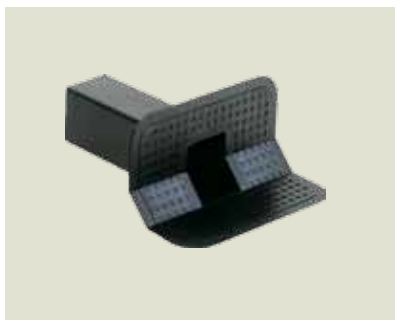

BOCCHETTONE ANGOLARE ANGOLO 45°
SEZIONE 100 X 100 mm
ANGULAR DRAIN 45° 100 x 100 mm SECTION

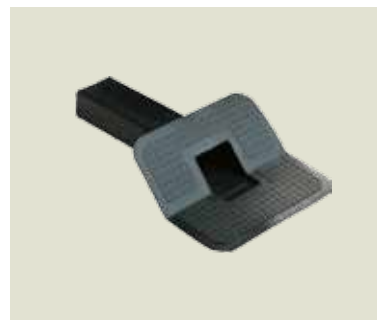

BOCCHETTONE ANGOLARE ANGOLO 45°
SEZIONE 100 X 65 mm
ANGULAR DRAIN 45° 100 x 65 mm SECTION



BOCCHETTONE ANGOLARE ANGOLO 90°
SEZIONE 100 X 65 mm
ANGULAR DRAIN 90° 100 x 65 mm SECTION



BOCCHETTONE ANGOLARE ANGOLO 90°
SEZIONE 100 X 100 mm
ANGULAR DRAIN 90° 100 x 100 mm SECTION

TPE

MBP



BOCCHETTONI ANGOLARI IN TPE RACCORDI PER BOCCHETTONE ANGOLARE

TPE ANGULAR
DRAINS - PIPE
ADAPTORS FOR
ANGULAR DRAIN

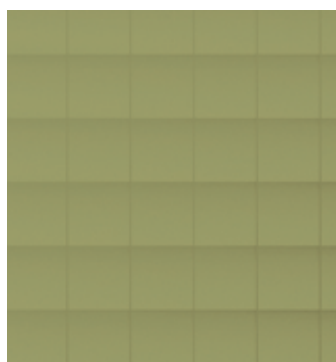

SEZIONE
100 X 100 MM
100 X 100 MM
SECTION

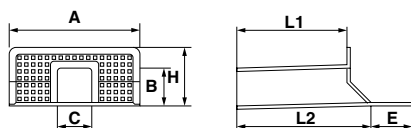

PRODOTTO / PRODUCT

Codice Code	Tipo Type	A	B	C	E	H	L1	L2	Pagina listino Price list page	Pz	Pz
A040415010	45°	340	92	92	105	168	375	415	12	5	80

SEZIONE
100 X 100 MM
100 X 100 MM
SECTION

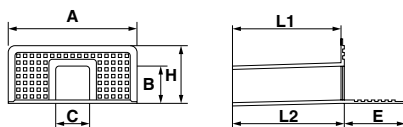

PRODOTTO / PRODUCT

Codice Code	Tipo Type	A	B	C	E	H	L1	L2	Pagina listino Price list page	Pz	Pz
A041375010	90°	340	92	92	145	168	375	375	12	5	80

RACCORDO SEZIONE
100 X 100 MM
PIPE ADAPTOR
100 X 100 MM SECTION

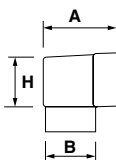

PRODOTTO / PRODUCT

Codice Code	Tipo Type	A	B	H	Pagina listino Price list page	Pz	Pz
F071080010	Ø 80	148	78	95	12	10	700
F071100010	Ø 100	148	96	96	12	10	700

T P E

M B P



SEZIONE
100 X 65 MM
100 X 65 MM
SECTION

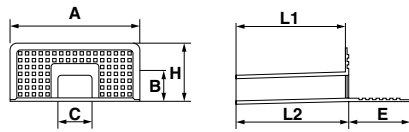

PRODOTTO / PRODUCT											
Codice Code	Tipo Type	A	B	C	E	H	L1	L2	Pagina listino Price list page	Pz	Pz
A042425065	90°	340	62	92	145	168	425	425	12	10	140

SEZIONE
100 X 65 MM
100 X 65 MM
SECTION

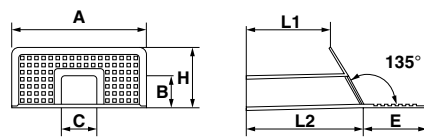

PRODOTTO / PRODUCT											
Codice Code	Tipo Type	A	B	C	E	H	L1	L2	Pagina listino Price list page	Pz	Pz
A040425065	135°	340	62	95	145	115	370	425	12	10	140

RACCORDO
SEZIONE
100 X 65 MM
PIPE ADAPTOR
100X65 MM
SECTION

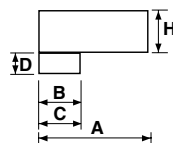

PRODOTTO / PRODUCT											
Codice Code	Misura Size	A	B	C	D	H	Pagina listino Price list page	Pz	Pz		
F072063080	Ø 63 - 80	218	63	80	45	65	12	10	360		
F072080100	Ø 80 - 100	218	80	100	62	65	12	10	360		

TPE

MBP



BOCCHETTONE ANGOLARE IN TPE CON CODOLO TONDO L 500 MM

TPE ANGULAR
DRAIN WITH
ROUND SPIGOT L
500 MM

Il bocchettone angolare con uscita tonda è provvisto di un codolo di scarico L 500 mm e può essere facilmente prolungato raccordandolo ad un normale tubo di plastica.

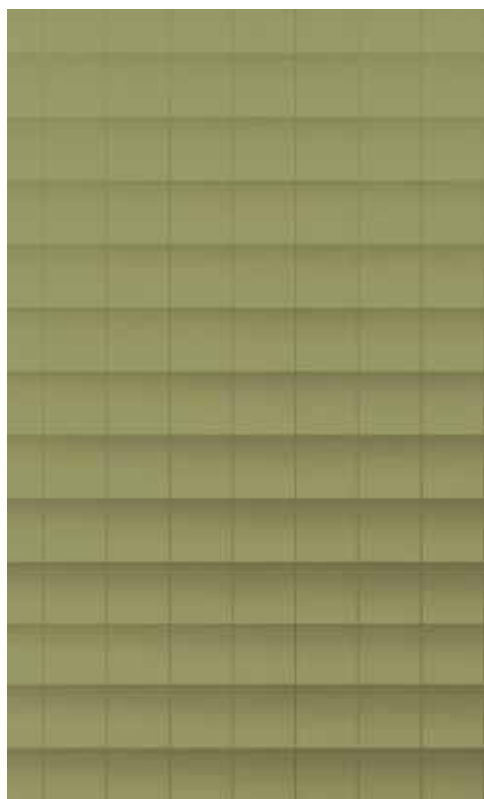

The angular roof drain with round exit spigot is provided with a 500 mm long drain spigot which could be easily made longer simply by using a standard plastic pipe.

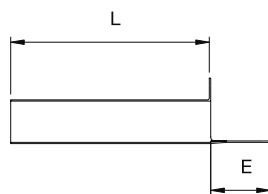
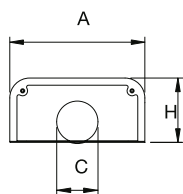

BOCCHETTONE ANGOLARE USCITA TONDA L 500 MM ANGULAR DRAIN WITH ROUND SPIGOT L 500 MM



PRODOTTO / PRODUCT

Codice Code	Per tubi For pipes	A	C	E	H	L	Pagina listino Price list page	 Pz	 Pz
A045500063	Ø 63	340	63	150	133	500	12	8	80
A045500075	Ø 75	340	75	150	133	500	12	8	80
A045500080	Ø 80	340	80	150	133	500	12	8	80
A045500090	Ø 90	340	90	150	165	500	12	8	80
A045500100	Ø 100	340	100	150	165	500	12	8	80
A045500110	Ø 110	340	110	150	165	500	12	8	80
A045500125	Ø 125	340	125	150	185	500	12	7	70

BOCCHETTONE ANGOLARE PER POGGIOLI

ANGULAR DRAIN FOR BALCONIES



BOCCHETTONE ANGOLARE PER POGGIOLI SEZIONE 57 X 78 MM
ANGULAR DRAIN FOR BALCONIES 57 X 78 MM SECTION

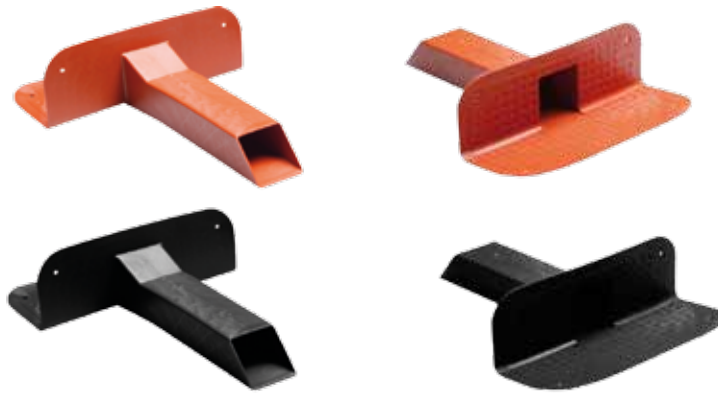
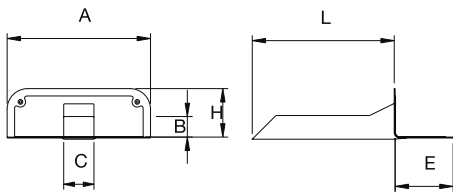

PRODOTTO / PRODUCT										
Codice Code	Colore Colour	A	B	C	E	H	L	Pagina listino Price list page	Pz	Pz
A043347001	Avorio White	348	57	78	140	120	347	13	5	140
A043347002	Rosso Brick-red	348	57	78	140	120	347	13	5	140
A043347003	Rame Copper	348	57	78	140	120	347	13	5	140
A043347004	Nero Black	348	57	78	140	120	347	13	5	140

BOCCHETTONE ANGOLARE PER POGGIOLI SEZIONE 57 X 48 MM
ANGULAR DRAIN FOR BALCONIES 57 X 48 MM SECTION

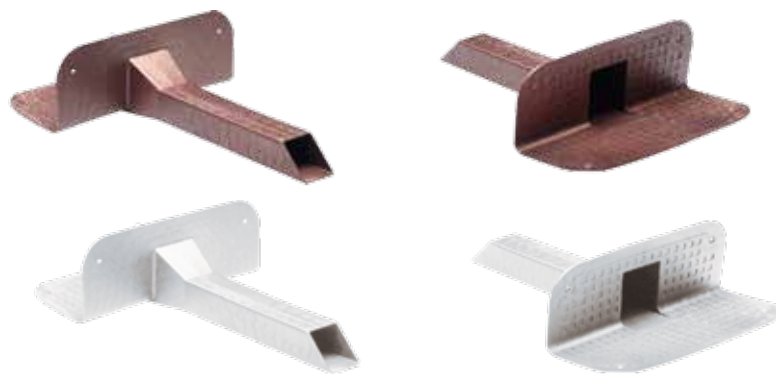
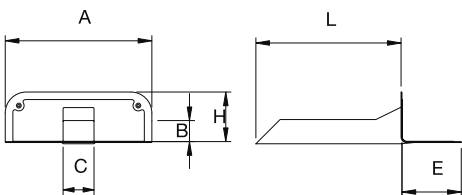

PRODOTTO / PRODUCT										
Codice Code	Colore Colour	A	B	C	E	H	L	Pagina listino Price list page	Pz	Pz
A043347101	Avorio White	348	48	57	140	120	347	13	5	140
A043347102	Rosso Brick-red	348	48	57	140	120	347	13	5	140
A043347103	Rame Copper	348	48	57	140	120	347	13	5	140
A043347104	Nero Black	348	48	57	140	120	347	13	5	140

ESALATORI IN TPE
PER MEMBRANE
IN BITUME
POLIMERO

TPE ROOF VENTS
FOR BITUMINOUS
MEMBRANES

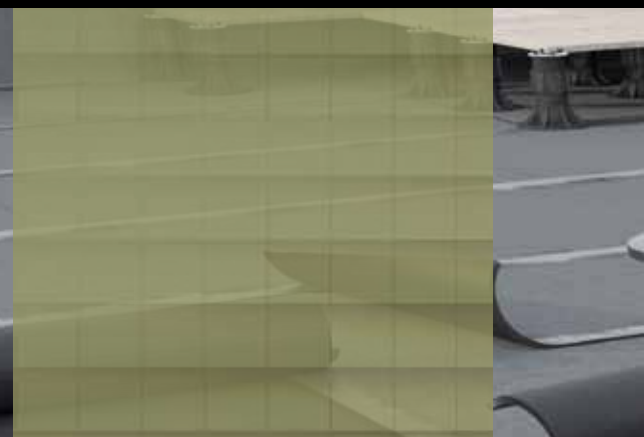
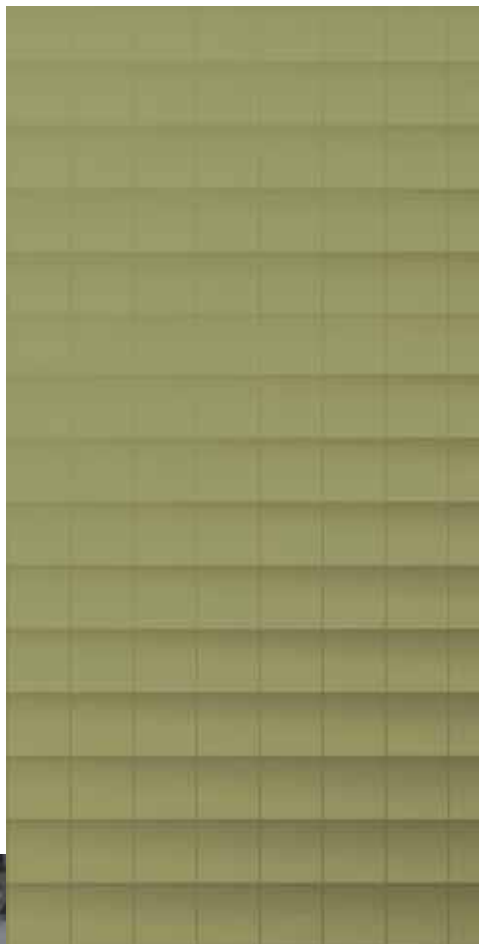

Gli esalatori in TPE sono accessori indispensabili per assicurare la fuoriuscita del vapore acqueo che si accumula al di sotto dello strato impermeabile in bitume polimero; questo importante accorgimento elimina il rischio di pericolosi rigonfiamenti del manto impermeabile che causano il distacco dell'impermeabilizzazione dal supporto o dal piano di posa.

In tal modo i solai si mantengono asciutti e le guaine acquisiscono longevità con estrema garanzia delle loro performance.



The TPE vents accessories are needed to ensure the vapor to escape from below the waterproofing bituminous membrane. This important device eliminates the risk of dangerous swelling and detachment from the subfloor of the waterproofing membrane.

In this way the structure is kept dry and waterproofing acquires extreme longevity with higher guarantee of its performance.

VANTAGGI:

- Alta resistenza alla fiamma
- Ampia flangia
- Ampia gamma di versioni

ADVANTAGES:

- Exceptional fire resistance
- Wide flange
- Wide range of versions



ESALATORI IN TPE PER MEMBRANE IN BITUME POLIMERO

TPE ROOF VENTS FOR BITUMINOUS MEMBRANES

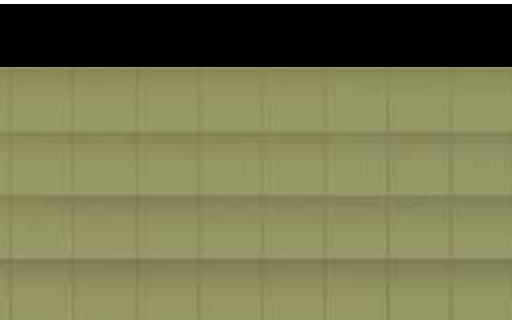

- 1** Cupola rinforzata
Reinforced dome
- 2** Protezione circolare
Protection collar
- 3** Speciale zigrinatura per favorire l'aggancio del bitume fuso
Special ribbing to facilitate the attachment of the cast bitumen
- 4** Punti di ancoraggio per il bitume fuso
Anchoring points for the cast bitumen

SPECIALI PUNTI DI APPOGGIO IN RILIEVO, A CONTATTO
CON IL PIANO DI POSA STUDIATI PER CONSENTIRE IL
PASSAGGIO DEL VAPORE
SPECIAL EMBOSSED SUPPORTING POINTS, IN CONTACT
WITH THE BASE DESIGNED TO LET STEAM PASS



VERSIONI TYPES



TPE

MBP



ESALATORI IN TPE SEMPLICI E DOPPI - PROTEZIONE CIRCOLARE

SIMPLE WALL AND DOUBLE WALL TPE ROOF VENTS - PROTECTION COLLAR





La funzione dell'esalatore è quella di permettere la fuoriuscita del vapore che si crea al di sotto della membrana impermeabile. Viene realizzato in due modelli: il tipo "semplice" che si usa in presenza della sola membrana impermeabile ed il tipo "doppio" che si usa in presenza di pannello isolante. Raccomandiamo sempre l'utilizzo dell'apposita protezione circolare.

The vent pipe allows moisture and vapour under waterproofing membrane to go out. It is available in the following models: the simple wall version used in case of a simple waterproofing membrane and the double wall version used in the presence of insulating panels. For a further protection, the use of the special protection collar is also recommended.

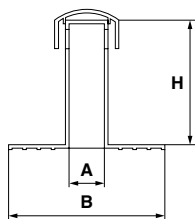
SEMPLICE
H 225/270 MM
SIMPLE WALL
H 225/270 MM





PRODOTTO / PRODUCT

Codice Code	Tipo Type	A	B	H	H1	Pagina listino Price list page	 Pz	 Pz
D011225060	Ø 62	60	300	225	-	14	30	270
D011225075	Ø 75	72	300	225	-	14	25	225
D014270075	Ø 75	72	300	270	-	14	25	225

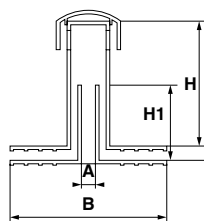
DOPPIO
H 225/270 MM
DOUBLE WALL
H 225/270 MM



PRODOTTO / PRODUCT

Codice Code	Tipo Type	A	B	H	H1	Pagina listino Price list page	 Pz	 Pz
D030225075	Ø 75	60	300	225	190	14	25	225
D030270075	Ø 75	60	300	270	190	14	25	225

TPE

MBP



SEMPLICE
H 400 MM
SIMPLE WALL
H 400 MM

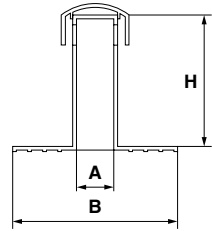

PRODOTTO / PRODUCT

Codice Code	Esterno External	A	B	H	H1	Pagina listino Price list page	Pz	Pz
D011400075	Ø 75	72	300	400	-	14	25	200

DOPPIO
H 400 MM
DOUBLE WALL
H 400 MM

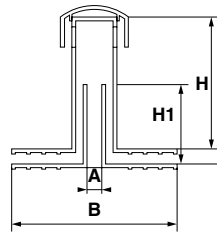

PRODOTTO / PRODUCT

Codice Code	Esterno External	A	B	H	H1	Pagina listino Price list page	Pz	Pz
D030400075	Ø 75	60	300	400	190	14	25	200

PROTEZIONE
CIRCOLARE
PROTECTION
COLLAR

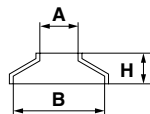

PRODOTTO / PRODUCT

Codice Code	Esterno External	A	B	H	Pagina listino Price list page	Pz	Pz
D150000000	-	75	180	60	14	25	1750

TPE

MBP



ESALATORE "MAXI" IN TPE SEMPLICE E DOPPIO

SIMPLE WALL AND DOUBLE WALL TPE "MAXI" ROOF VENT



Anche l'esalatore "Maxi" è realizzato in due modelli: il tipo "semplice" che si usa in presenza della sola membrana impermeabile, il tipo "doppio" che si usa in presenza di un pannello isolante. Raccomandiamo sempre l'utilizzo dell'apposita protezione circolare.

The "Maxi" type vent pipe is also available in two different versions, the simple wall version used in case of a simple waterproofing membrane and a double wall version used in the presence of insulating boards. For a further protection, the use of the special protection collar is also recommended.

"MAXI" SEMPLICE
H 270 MM
SIMPLE WALL
"MAXI" SIMPLE
WALL H 270 MM

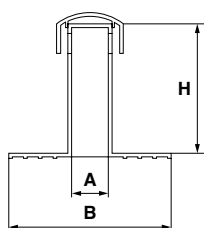

PRODOTTO / PRODUCT

Codice Code	Esterno External	A	B	H	Pagina listino Price list page	Pz	
D015270110	Ø 105	100	300	270	15	20	180

"MAXI" DOPPIO
H 270 MM
"MAXI" DOUBLE WALL
H 270 MM

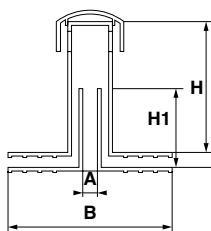

PRODOTTO / PRODUCT

Codice Code	Esterno External	A	B	H	H1	Pagina listino Price list page	Pz	
D033270110	Ø 105	60	300	270	190	15	20	180

ESALATORE IN TPE COIBENTATO SEMPLICE E DOPPIO - PROTEZIONE CIRCOLARE

INSULATED SIMPLE WALL AND DOUBLE WALL TPE ROOF VENT - PROTECTION COLLAR



L'esalatore coibentato, grazie alla coibentazione in polistirolo presente nella parete esterna, elimina il rischio di condensa dovuto alla differenza di temperatura fra l'ambiente interno ed esterno. Anche l'esalatore coibentato è disponibile nei modelli "semplice" e "doppio" ed è completato dalla protezione circolare.

Thanks to the internal polystyrene insulation body, which allows the moisture to get out through the dome more easily, this type of vent pipe eliminates any risk of condensation due to the difference in temperature between the outside and the inside. Available in the "simple" and "double wall" versions with a proper protection collar.

COIBENTATO SEMPLICE H 225 MM
INSULATED SIMPLE WALL H 225 MM

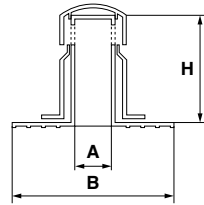

PRODOTTO / PRODUCT								
Codice Code	Esterno External	A	B	H	Pagina listino Price list page			
D040225075	Ø 105	72	300	225	15	20	180	

COIBENTATO DOPPIO H 225 MM
INSULATED DOUBLE WALL H 225 MM

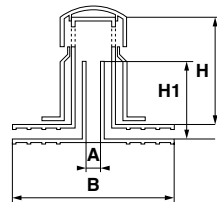

PRODOTTO / PRODUCT									
Codice Code	Esterno External	A	B	H	H1	Pagina listino Price list page			
D050225075	Ø 105	60	300	225	190	15	20	180	

PROTEZIONE CIRCOLARE
PROTECTION COLLAR

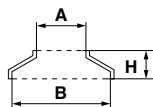

PRODOTTO / PRODUCT								
Codice Code	Esterno External	A	B	H	Pagina listino Price list page			
D160000000	-	105	205	60	15	20	1400	

TPE

MBP



ESALATORE "STANDARD" PER TEGOLA CANADESE

"STANDARD" TYPE AIR VENT FOR SHINGLES



L'esalatore per tegola canadese "Standard" è la versione più tradizionale e conosciuta di questo accessorio.

The air vent "Standard" type for shingle is the most traditional and common type of this item.

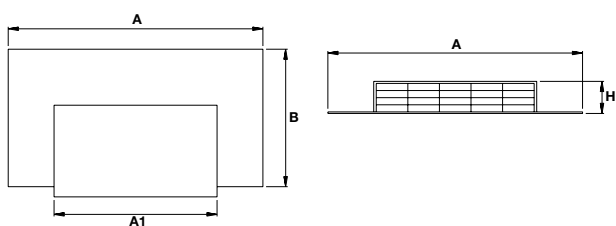

PRODOTTO / PRODUCT

Codice Code	Tipo Type	A	B	A ₁	H1	Pagina listino Price list page	Pz	Pz
D50000010	Nero Black	500	267	300	60	16	38	-



PRODOTTO / PRODUCT

Codice Code	Tipo Type	A	B	A ₁	H1	Pagina listino Price list page	Pz	Pz
D50000020	Rosso mattone Brick-red	500	267	300	60	16	38	-



PRODOTTO / PRODUCT

Codice Code	Tipo Type	A	B	A ₁	H1	Pagina listino Price list page	Pz	Pz
D50000030	Verde Green	500	267	300	60	16	30	-

RACCORDO PER TUBI IN TPE E IN GOMMA EPDM - RACCORDO CONICO IN TPE

EPDM RUBBER AND TPE BASE FITTINGS FOR PIPES - TPE CONICAL BASE FITTING FOR PIPES

TPE

MBP

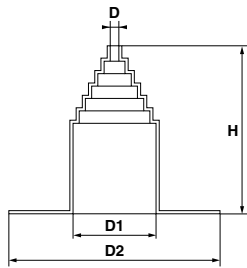

PRODOTTO / PRODUCT								
Codice Code	Tipo Type	D	D1	D	H	Pagina listino Price list page	Pz	Pz
F004000000	Gomma EPDM EPDM Rubber	15	130	330	250	16	15	240

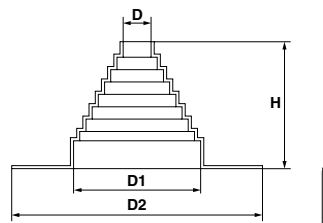

PRODOTTO / PRODUCT								
Codice Code	Tipo Type	D	D1	D	H	Pagina listino Price list page	Pz	Pz
F001000000	TPE	40	175	395	190	16	12	360

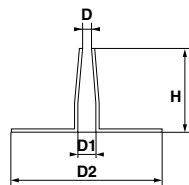



PRODOTTO / PRODUCT								
Codice Code	Tipo Type	D	D1	D	H	Pagina listino Price list page	Pz	Pz
F013000000	TPE	15	30	210	120	16	50	2100

TPE

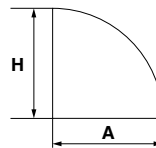

ANGOLI
IN TPE

MBP

TPE
CORNERSANGOLO INTERNO "MEDIO"
INTERNAL CORNER "MEDIUM"

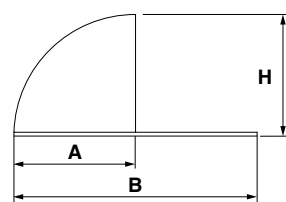
PRODOTTO / PRODUCT						
Codice Code	A	B	H	Pagina listino Price list page	 Pz	 Pz
F011001100	95	-	95	17	200	6000*

ANGOLO ESTERNO "MEDIO"
EXTERNAL CORNER "MEDIUM"



PRODOTTO / PRODUCT						
Codice Code	A	B	H	Pagina listino Price list page	 Pz	 Pz
F010001100	93	173	100	17	100	3000*

* Dimensioni pallet: mm 1200 x 800 x h 1100
Pallet size: mm 1200 x 800 x h 1100

SUPPORTO ORIENTABILE IN PP
PER RETE PARAFULMINE

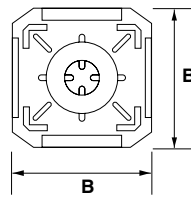
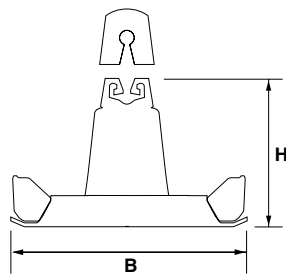
PP ORIENTABLE SUPPORT FOR
LIGHTNING-CONDUCTOR NET



PRODOTTO / PRODUCT						
Codice Code	Tipo Type	B	H	Pagina listino Price list page		
F16000000	Supporto Support	15	10	17	-	-
F16100000	Cappuccio Cap	-	-	17	-	-

BOCCHETTONE
PER MEMBRANE
SINTETICHE

DRAIN HOLE
FOR SYNTHETIC
MEMBRANES

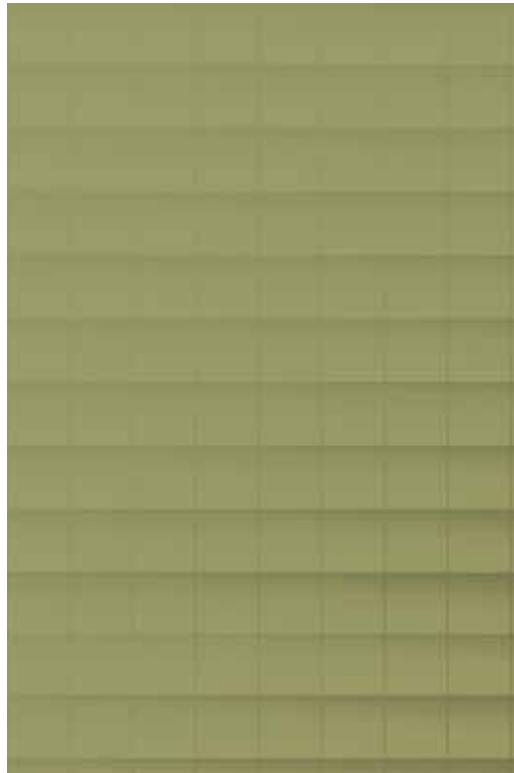

Una linea completa di accessori interamente costruiti in materiale sintetico che per le sue caratteristiche di efficacia, resistenza e durata sta diventando sempre più richiesto nelle impermeabilizzazioni.

Tutti elementi progettati, realizzati e testati dagli specialisti delle coperture impermeabili.

Gli accessori Eterno Ivica in materiale sintetico possono essere utilizzati in tutte le coperture piane: a tetto sia caldo sia rovescio, zavorrate e non zavorrate.



A complete line of accessories made entirely from synthetic material. Thanks to its effectiveness, strength and durability, is becoming increasingly used as a waterproofing material.

All the elements are designed, manufactured and tested by specialists in the field of waterproof roofing.

Eterno Ivica's accessories can be used for all types of flat roofing applications: whether hot, reverse, ballasted or non-ballasted.

VANTAGGI:

- Adattabile a qualsiasi tipo di pluviale di scarico
- Ampia flangia
- Ampia gamma di misure da Ø 63 mm a Ø 160 mm

ADVANTAGES:

- Adaptable to any type of drainpipe
- Wide flange
- Wide range of sizes, from Ø 63 mm to Ø 160 mm



BOCCHETTONE "EURO" PER MEMBRANE SINTETICHE

"EURO" DRAIN FOR SYNTHETIC MEMBRANES



- 1** Predisposizione per l'inserimento di parafoglie
Predisposed for the installation of leaf-guards
- 2** Alta resistenza alle basse temperature
Exceptional resistance to low temperatures
- 3** Codolo h 250 e 400 mm
250 mm and 400 mm H spigot
- 4** Coppie di speciali alette antireflusso spessore 10 mm
Two special backflow prevention flaps thickness 10 mm

VERSIONI TYPES



PVC

PVC

SSS

BOCCHETTONE "EURO" IN PVC CON CODOLO H 250 MM E 400 MM

"EURO" PVC ROOF DRAIN WITH A 250 OR 400 MM SPIGOT

Realizzati in PVC, resistenti alle basse temperature (flessibilità a freddo = -40°), sono compatibili con qualsiasi membrana impermeabile in PVC. La flangia è liscia, in modo da consentire una perfetta fusione con le membrane impermeabili. Il codolo è dotato di due o tre coppie di alette antiriflusso, a seconda che sia lungo 250 mm o 400 mm.

Manufactured of PVC, it is highly resistant against low temperatures (cold flexibility = -40°) as well as perfectly compatible with any sort of PVC membrane. The flange is totally smooth for a perfect bonding to the waterproofing sheet. According to the length of 250 or 400 mm, the spigot is provided with two or three couples of anti-infiltration rings.

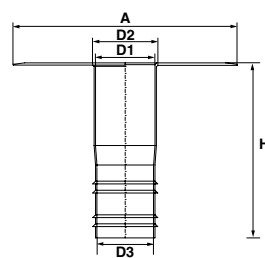
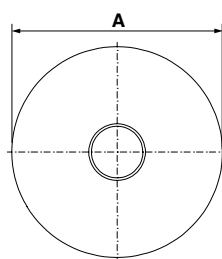

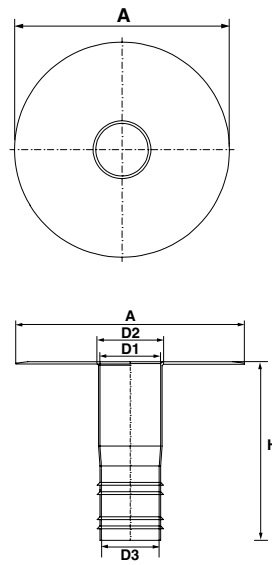

BOCCHETTONE H 250 MM ROOF DRAIN H 250 MM

PRODOTTO / PRODUCT									
Codice Code	Per tubi For pipes	A	D1	D2	D3	H	Pagina listino Price list page		
A014025063	Ø 63	320	51	60	49	250	18	15	240
A014025075	Ø 75	320	63	70	62	250	18	15	240
A014025082	Ø 82	320	69	75	68	250	18	15	240
A014025090	Ø 90	320	80	84	79	250	18	15	240
A014025100	Ø 100	320	86	90	85	250	18	15	240
A014025110	Ø 110	380	95	101	94	250	18	15	240
A014025125	Ø 125	380	109	115	108	250	18	15	240
A014025140	Ø 140	380	128	134	127	250	18	10	160
A014025150	Ø 150	380	134	140	132	250	18	10	160
A014025160	Ø 160	380	140	146	139	250	18	8	128



BOCCHETTONE H 400 MM
ROOF DRAIN H 400 MM

PRODOTTO / PRODUCT

Codice Code	Per tubi For pipes	A	D1	D2	D3	H	Pagina listino Price list page	 Pz	 Pz
A014040063	Ø 63	320	51	60	49	400	18	15	240
A014040075	Ø 75	320	63	70	62	400	18	15	240
A014040082	Ø 82	320	69	75	68	400	18	15	240
A014040090	Ø 90	320	80	84	79	400	18	15	240
A014040100	Ø 100	320	86	90	85	400	18	8	128
A014040110	Ø 110	380	95	101	94	400	18	8	128
A014040125	Ø 125	380	109	115	108	400	18	8	128
A014040140	Ø 140	380	128	134	127	400	18	4	64
A014040150	Ø 150	380	134	140	132	400	18	4	64
A014040160	Ø 160	380	140	146	139	400	18	4	64

PVC

BOCCHETTONI ANGOLARI IN PVC

PVC

SSS

PVC ANGULAR DRAINS

Realizzati in PVC, sono compatibili con qualsiasi membrana impermeabile in PVC.

Manufactured of PVC, they are perfectly compatible with any sort of PVC membrane.

SEZIONE 100 X 100 MM 100 X 100 MM SECTION

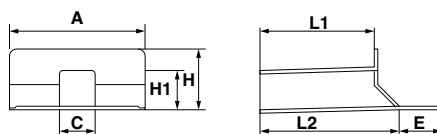

PRODOTTO / PRODUCT

Codice Code	Tipo Type	Misura Size	A	C	E	H	H1	L1	L2	Pagina listino Price list page	Pz	Pz
A060415010	45°	45°	340	92	105	168	92	375	415	19	5	80

SEZIONE 100 X 100 MM 100 X 100 MM SECTION

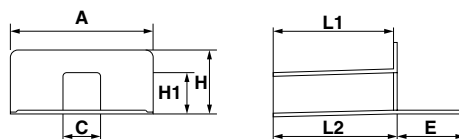

PRODOTTO / PRODUCT

Codice Code	Tipo Type	Misura Size	A	C	E	H	H1	L1	L2	Pagina listino Price list page	Pz	Pz
A061375010	90°	90°	340	92	145	168	92	375	375	19	5	80

RACCORDO SEZIONE 100 X 100 MM PIPE ADAPTOR 100 X 100 MM SECTION

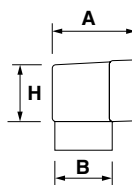

PRODOTTO / PRODUCT

Codice Code	Misura Size	A	B	H	Pagina listino Price list page	Pz	Pz
F071080010	Ø 80	148	78	95	19	10	700
F071100010	Ø 100	148	96	96	19	10	700



PVC

PVC

SSS

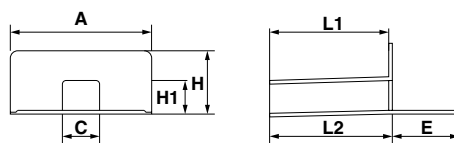

SEZIONE 100 X 65 MM
100 X 65 MM SECTION



PRODOTTO / PRODUCT											
Codice Code	Tipo Type	A	C	E	H	H1	L1	L2	Pagina listino Price list page		
A062425065	90°	340	92	145	168	62	425	425	19	8	112

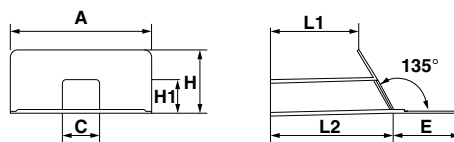

SEZIONE 100 X 65 MM
100 X 65 MM SECTION

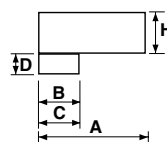

PRODOTTO / PRODUCT											
Codice Code	Tipo Type	A	C	E	H	H1	L1	L2	Pagina listino Price list page		
A060425065	135°	340	95	145	115	62	340	425	19	10	140

RACCORDO SEZIONE 100 X 65 MM
PIPE ADAPTOR 100 X 65 MM SECTION



PRODOTTO / PRODUCT											
Codice Code	Misura Size	A	B	C	D	H	Pagina listino Price list page				
F072063080	Ø 63 - 80	218	63	80	45	65	19	10	360		
F072080100	Ø 80 - 100	218	80	100	62	65	19	10	360		

PVC

PVC

SSS

BOCCHETTONI ANGOLARI IN PVC CON CODOLO TONDO E PER POGGIOLI

PVC ANGULAR DRAIN WITH ROUND SPIGOT FOR BALCONIES





Realizzati in PVC, resistenti alle basse temperature (flessibilità a freddo = -40°), sono compatibili con qualsiasi membrana impermeabile in PVC. La flangia è liscia, in modo da consentire una perfetta fusione con le membrane impermeabili.

Manufactured of PVC, it is highly resistant against low temperatures (cold flexibility = -40°) as well as perfectly compatible with any sort of PVC membrane. The flange is totally smooth for a perfect bonding to the waterproofing sheet.

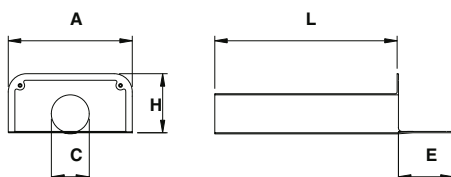

BOCCHETTONE ANGOLARE USCITA TONDA ANGULAR DRAIN WITH ROUND SPIGOT

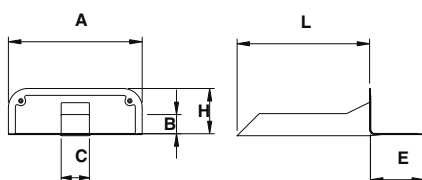

PRODOTTO / PRODUCT									
Codice Code	Per tubi For pipes	A	C	E	H	L	Pagina listino Price list page		
A046500063	Ø 63	340	63	150	133	500	19	8	80
A046500075	Ø 75	340	75	150	133	500	19	8	80
A046500090	Ø 90	340	90	150	165	500	19	8	80
A046500110	Ø 110	340	110	150	165	500	19	8	80
A046500125	Ø 125	340	125	150	165	500	19	7	70

SEZIONE 57 X 78 MM 57 X 78 MM SECTION



PRODOTTO / PRODUCT										
Codice Code	Tipo Type	A	B	C	E	H	L	Pagina listino Price list page		
A044347000	Grigio Grey	348	57	78	140	120	347	20	5	140

ESALATORI IN PVC SEMPLICI E DOPPI - PROTEZIONE CIRCOLARE

SIMPLE WALL AND DOUBLE WALL PVC ROOF VENTS - PROTECTION COLLAR

PVC

PVC

SSS

Perfettamente compatibile con qualsiasi membrana impermeabile in PVC è realizzato in due modelli, il tipo "semplice", che si usa solo in presenza di membrana impermeabile, il tipo "doppio" che si usa nel caso venga applicato un pannello isolante. Raccomandiamo l'uso dell'apposita protezione circolare.

Perfectly compatible with all sorts of PVC membrane, it's available in the following models: the simple wall version used in case of a simple waterproofing membrane and the double wall version used in the presence of insulating panels. For a further protection, a specific collar is also provided.

SEMPLICE SIMPLE WALL

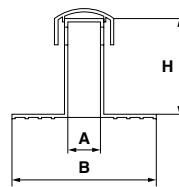

PRODOTTO / PRODUCT								
Codice Code	Ø esterno Ø external	A	B	H	Pagina listino Price list page	Pz	Pz	Pz
D070225075	75	72	300	225	20	20	180	

DOPPIO DOUBLE

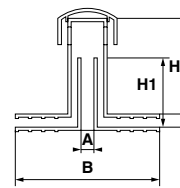

PRODOTTO / PRODUCT								
Codice Code	Ø esterno Ø external	A	B	H	H1	Pagina listino Price list page	Pz	Pz
D080225075	75	60	300	225	190	20	20	180

PROTEZIONE CIRCOLARE PROTECTION COLLAR

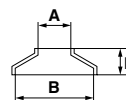

PRODOTTO / PRODUCT								
Codice Code	Tipo Type	Ø esterno Ø external	A	B	H	Pagina listino Price list page	Pz	Pz
D150000000	Protezione circolare Ø 75 mm Protection collar Ø 75 mm	-	75	180	60	20	25	1750
D160000000	Protezione circolare Ø 110 mm Protection collar Ø 110 mm	-	105	205	60	20	20	1400



PVC

ESALATORI IN PVC SEMPLICI
E DOPPI - PROTEZIONE CIRCOLARE

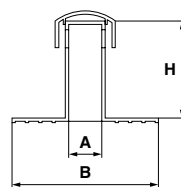

PVC

SSS

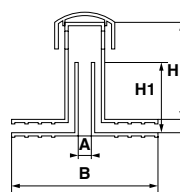

SIMPLE WALL AND DOUBLE WALL PVC
ROOF VENTS - PROTECTION COLLARSEMPLICE
SIMPLE WALL

PRODOTTO / PRODUCT								
Codice Code	Ø esterno Ø external	A	B	H	Pagina listino Price list page			
D070400075	75	72	300	400	20	12	96	

DOPPIO
DOUBLE

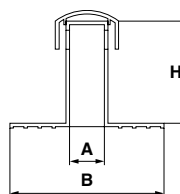
PRODOTTO / PRODUCT								
Codice Code	Ø esterno Ø external	A	B	H	H1	Pagina listino Price list page		
D080400075	75	60	300	400	190	20	12	96

"MAXI" SEMPLICE
"MAXI" SIMPLE WALL

PRODOTTO / PRODUCT								
Codice Code	Ø esterno Ø external	A	B	H	H1	Pagina listino Price list page		
D070270110	105	100	300	270	190	20	15	135

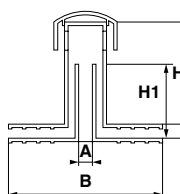
"MAXI" DOPPIO
"MAXI" DOUBLE

PRODOTTO / PRODUCT								
Codice Code	Ø esterno Ø external	A	B	H	H1	Pagina listino Price list page		
D101270110	105	60	300	270	190	20	15	135

ESALATORI IN PVC COIBENTATO - PROTEZIONE CIRCOLARE

INSULATED SIMPLE AND DOUBLE WALL PVC ROOF VENTS - PROTECTION COLLAR

PVC

PVC



SSS

L'esalatore coibentato, grazie alla coibentazione in polistirolo presente nella parete esterna, elimina il rischio di condensa dovuto alla differenza di temperatura fra l'ambiente interno ed esterno. Come per tutti gli altri modelli, anche l'esalatore coibentato è disponibile nei modelli "semplice" e "doppio" ed è completato dalla protezione circolare.

Thanks to the internal polystyrene insulation body, which allows the moisture to get out through the dome more easily, this type of vent pipe eliminates any risk of condensation due to the difference in temperature between the outside and the inside. As for all the other vent pipes, it is also available in the "simple" and "double wall" versions along with a proper protection collar.

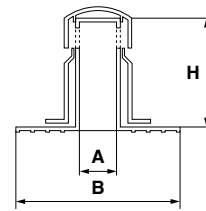

SEMPLICE SIMPLE WALL



PRODOTTO / PRODUCT								
Codice Code	Ø esterno Ø external	A	B	H	Pagina listino Price list page			
D090225075	107	72	300	225	21	20	180	

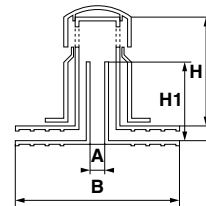

DOPPIO DOUBLE

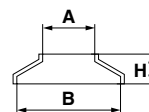

PRODOTTO / PRODUCT								
Codice Code	Ø esterno Ø external	A	B	H	H1	Pagina listino Price list page		
D100225075	107	60	300	225	190	21	20	180

PROTEZIONE CIRCOLARE PROTECTION COLLAR



PRODOTTO / PRODUCT								
Codice Code	Ø esterno Ø external	A	B	H	Pagina listino Price list page			
D160000000	-	105	205	60	21	20	1400	

PVC

ANGOLI INTERNI
ED ESTERNI IN PVC

PVC

PVC INTERNAL AND
EXTERNAL CORNER

SSS

Gli angoli interni ed esterni in PVC sono elementi estremamente importanti e necessari al completamento di una impermeabilizzazione con membrane monostrato in PVC. Servono infatti a proteggere e rinforzare gli spigoli e gli angoli presenti nella copertura da impermeabilizzare per esempio in presenza di muri e lucernari. La gamma "Eterno" si compone di 3 distinti modelli, diversi tra loro per dimensioni. I modelli "Mini" con una altezza di 70 mm, sono la soluzione più economica della gamma. Il modello "Medio" ha un'altezza di 95 mm. È questo il modello sicuramente più venduto. L'esclusiva versione "Maxi" è infine un modello unico per ampiezza di dimensioni con un'altezza di ben 150 mm per offrire una superficie impermeabilizzante davvero fuori standard.

PVC internal and external corners are element of a high importance and needed to finish a waterproofing with single-ply PVC membranes. The main purpose of these items is to protect and reinforce the waterproofing sheet on corners and edges (internal and external corners) like for example in presence of walls and skylights. The "Eterno" range offers 3 different types of corners with different sizes. Brand "Mini" type is only 70 mm high and is the cheaper version in the range. The "Medium" version is 95 mm height. This is for sure the most popular and used type. Thanks to its large surface (150 mm high), the exclusive "Maxi" type is ultimately a unique version that offers a very wide waterproofing area.

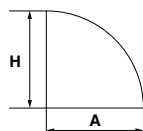
ANGOLO INTERNO "MINI"
INTERNAL CORNER "MINI"

PRODOTTO / PRODUCT						
Codice Code	A	B	H	Pagina listino Price list page	Pz	Pz
F011000200	70	-	70	22	350	-

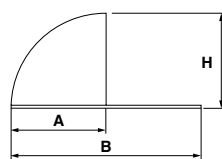
ANGOLO ESTERNO "MINI"
EXTERNAL CORNER "MINI"

PRODOTTO / PRODUCT						
Codice Code	A	B	H	Pagina listino Price list page	Pz	Pz
F010000200	67	128	70	22	200	-

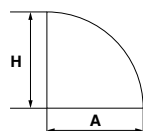
ANGOLO INTERNO "MEDIO"
INTERNAL CORNER "MEDIUM"

PRODOTTO / PRODUCT						
Codice Code	A	B	H	Pagina listino Price list page	Pz	Pz
F011000100	95	-	95	22	200	6000*

PVC

PVC

SSS

ANGOLO ESTERNO "MEDIO"
EXTERNAL CORNER "MEDIUM"

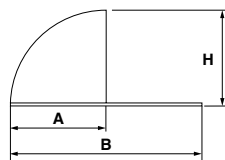

PRODOTTO / PRODUCT						
Codice Code	A	B	H	Pagina listino Price list page	Pz	Pz
F010000100	93	173	100	22	100	3000*

ANGOLO INTERNO "MAXI"
INTERNAL CORNER "MAXI"

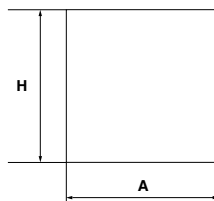

PRODOTTO / PRODUCT						
Codice Code	A	B	H	Pagina listino Price list page	Pz	Pz
F011000030	150	-	150	22	80	1600*

ANGOLO ESTERNO "MAXI"
EXTERNAL CORNER "MAXI"

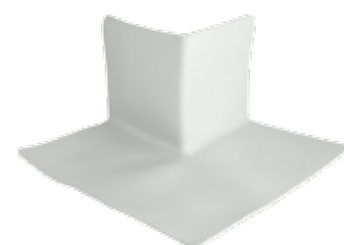
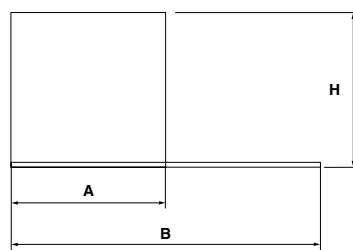

PRODOTTO / PRODUCT						
Codice Code	A	B	H	Pagina listino Price list page	Pz	Pz
F010000030	150	300	150	22	40	800*

* Dimensioni pallet mm 1200 x 800 x h 1100
Pallet size mm 1200 x 800 x h 1100



RACCORDI IN PVC



PVC BASE FITTING



I raccordi vengono applicati nei casi in cui fuoriescano dei tubi di sfiato dal solaio di copertura. L'applicazione è molto semplice: basta tagliare in corrispondenza della sezione richiesta, inserirlo all'esterno del tubo e sigillare mediante fascetta metallica stringitubo.

The fittings should be applied in cases where the vent pipes come out of the roofing floor. Application is very easy: simply cut according to the section required, slip it on the pipe and seal using a metal pipe clamp.

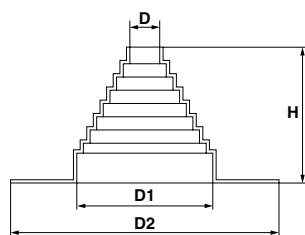
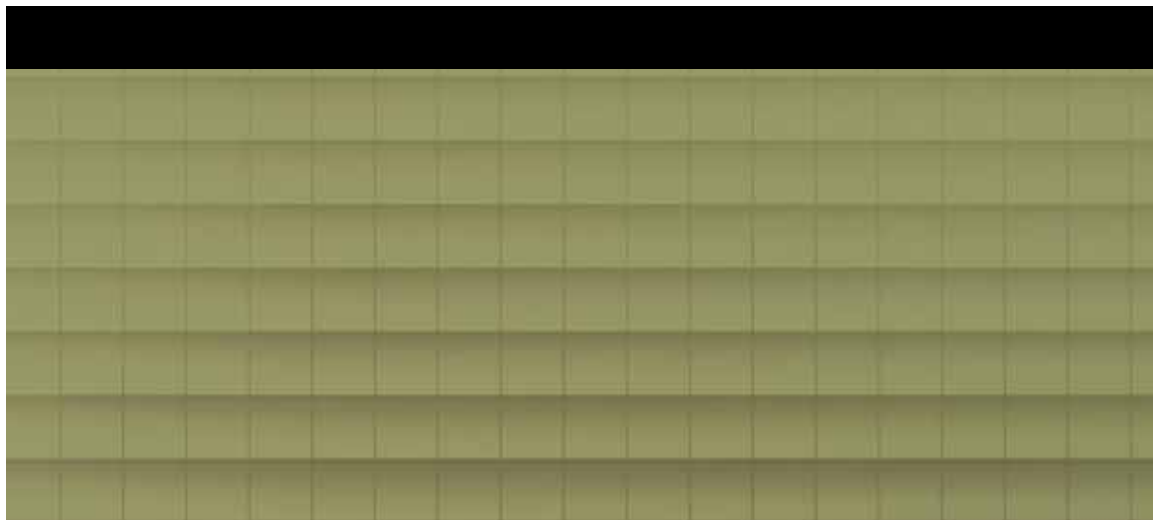

RACCORDO PER TUBI IN PVC PVC BASE FITTING FOR PIPES

PRODOTTO / PRODUCT							
Codice Code	D	D1	D2	H	Pagina listino Price list page	Pz	Pz
F002000000	40	175	395	190	22	12	360

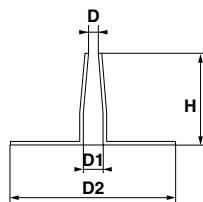

RACCORDO CONICO IN PVC PVC CONICAL BASE FITTING FOR PIPES

PRODOTTO / PRODUCT							
Codice Code	D	D1	D2	H	Pagina listino Price list page	Pz	Pz
F012000000	15	30	210	120	22	50	2100

BOCCHETTA PVC PROVA PRESSIONE

PVC PRESSURE TEST ELEMENT

PVC



PVC

SSS

La bocchetta PVC prova pressione è un elemento indispensabile per il collaudo delle saldature a "doppia pista" delle membrane sintetiche in PVC.

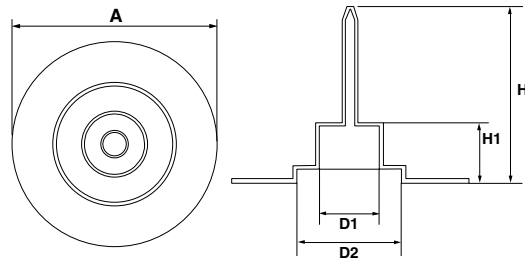
The PVC pressure test element is a new and essential item to test the pressure seal in the "double lane" overlaps made with pvc synthetic sheets.



PRODOTTO / PRODUCT									
Codice Code	A	D1	D2	H	H1	Pagina listino Price list page	 Pz	 Pz	
F10000000	177	30	73	40	65	23	100	2000	

PROFILI PERIMETRALI PER MEMBRANE IN PVC

PROFILES FOR PVC MEMBRANES



1 Profilo a parete
sviluppo 70 mm - lunghezza 2 mt
Perimetral wall profile
height 70 mm - length 2 mt

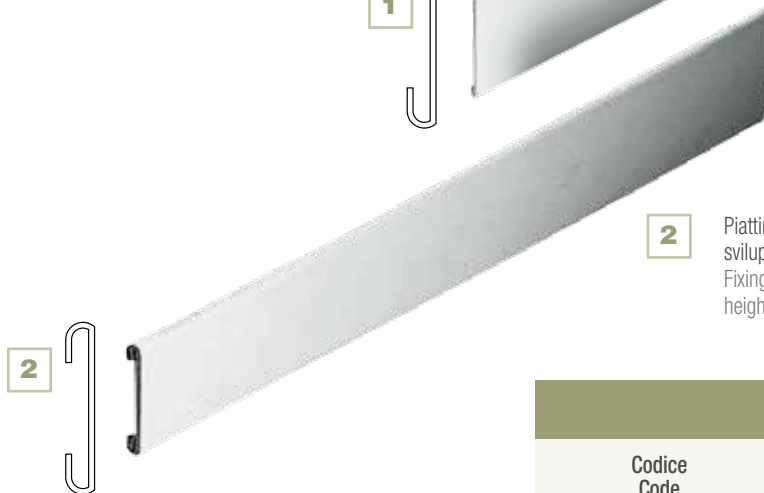

2 Piattina di fissaggio
sviluppo 50 mm - lunghezza 2 mt
Fixing flat element
height 50 mm - length 2 mt

PRODOTTO / PRODUCT				
Codice Code	Tipo Type	Pagina listino Price list page	 m	 Pz
F041007002	70 mm	23	2	-
F040005002	50 mm	23	2	-

ACCESSORI PER MANTI IMPERMEABILI IN POLIOLEFINE (TPO)

ACCESSORIES FOR TPO LAYERS



Thanks to its effectiveness, strength and durability, Thermoplastic Polyolefin (TPO) is becoming increasingly used as a waterproofing material.

Eterno Ivica has been manufacturing specific accessories for synthetic roofing felts since these types of materials appeared on the market, and has thus succeeded in acquiring unrivalled technical expertise.

Eterno Ivica's TPO accessories can be used for all types of flat roofing applications: whether hot, reverse, ballasted or non-ballasted.



Per le sue caratteristiche di efficacia, resistenza e durata, il Poliolefine TPO sta diventando un materiale sempre più richiesto nelle impermeabilizzazioni.

Eterno Ivica produce accessori specifici per guaine sintetiche sin dall'apparire sul mercato di questa tipologia di materiali: ecco perché ha acquisito un'esperienza tecnica insuperabile.

Gli accessori Eterno Ivica in TPO possono essere utilizzati in tutte le coperture piane: a tetto sia caldo sia rovescio, zavorrate e non zavorrate.

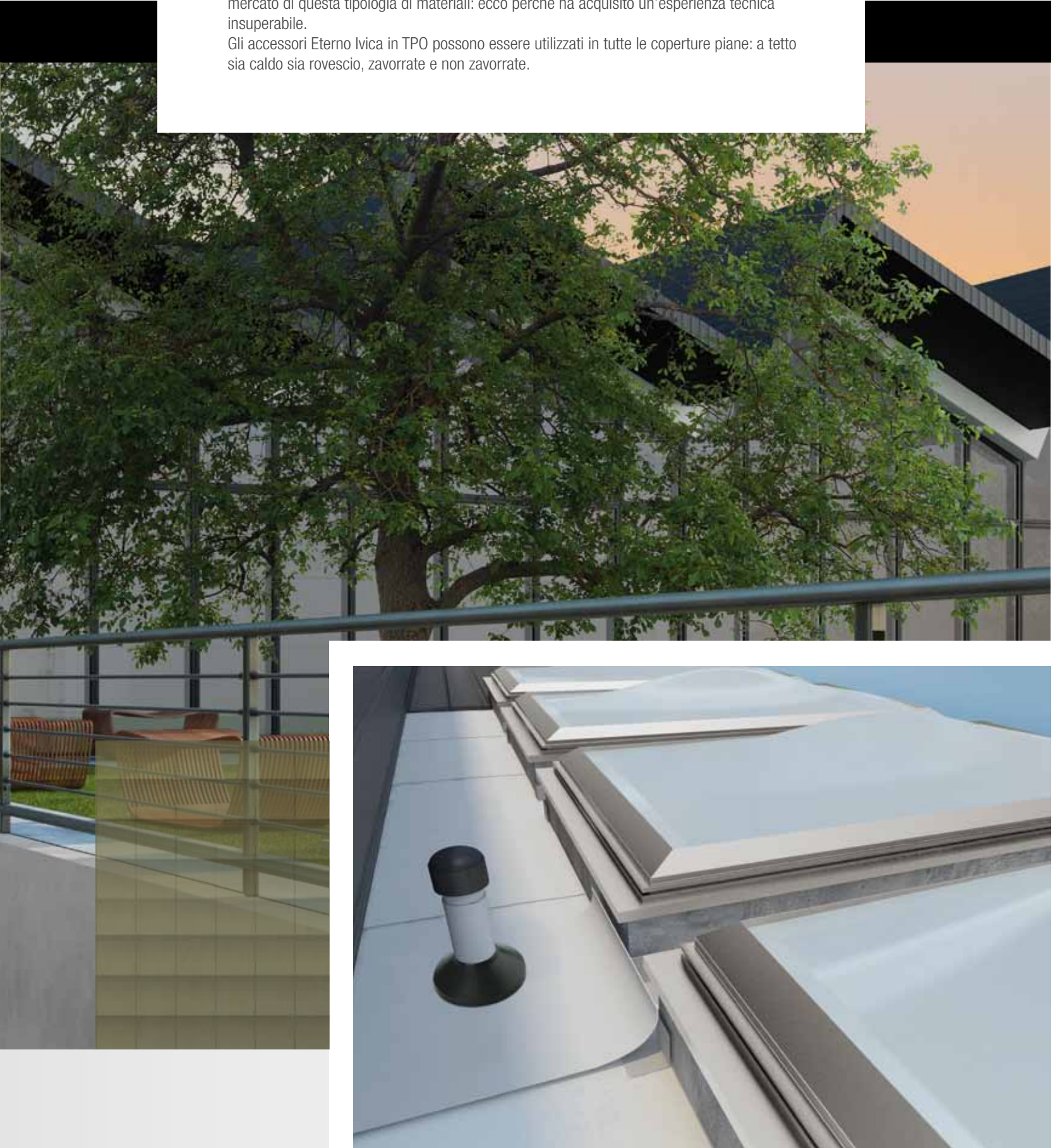

TPO

TPO

SSS

BOCCHETTONE "EURO" IN POLIOLEFINE (TPO) CON CODOLO H 250 MM



"EURO" ROOF DRAIN
MADE OF POLYOLEFENE
(TPO) WITH A 250 MM
SPIGOT

Realizzati in Poliolefine universale di colore bianco, sono creati per garantire la massima compatibilità con qualsiasi membrana in Poliolefine. La flangia è liscia per consentire una perfetta fusione con le membrane impermeabili. Il codolo è dotato di due coppie di alette antiriflusso.

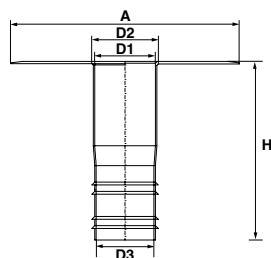
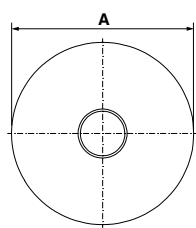
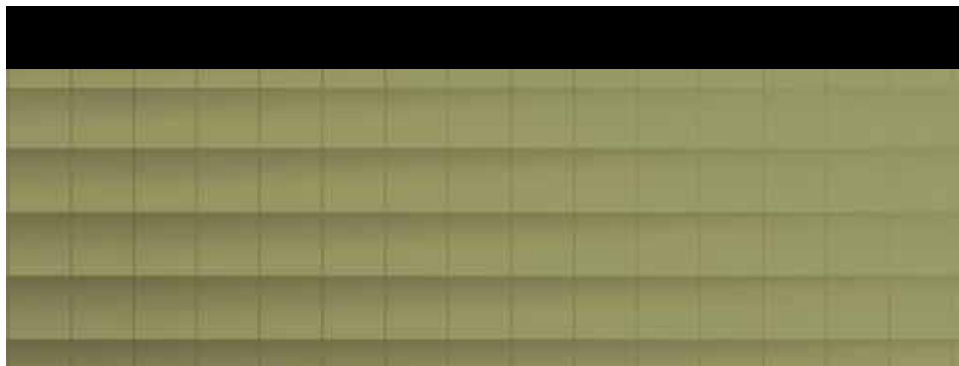
Manufactured of universal Polyolefine white, they are made to guarantee a perfect compatibility to any sort of TPO waterproofing membrane. The flange is totally smooth for a perfect bonding to the waterproofing membrane. The spigot is provided with two couples of anti - infiltration tongues.



PRODOTTO / PRODUCT

Codice Code HIFAX	Codice Code ADFLEX*	Per tubi For pipes	A	D1	D2	D3	H	Pagina listino Price list page		
A015225063	A015025063	63	320	51	60	49	250	24	15	240
A015225075	A015025075	75	320	63	70	62	250	24	15	240
A015225082	A015025082	82	320	69	75	68	250	24	15	240
A015225090	A015025090	90	320	80	84	79	250	24	15	240
A015225100	A015025100	100	320	86	90	85	250	24	15	240
A015225110	A015025110	110	380	95	101	94	250	24	15	240
A015225125	A015025125	125	380	109	115	108	250	24	15	240
A015225140	A015025140	140	380	128	134	127	250	24	10	160
A015225150	A015025150	150	380	134	140	132	250	24	10	160
A015225160	A015025160	160	380	140	146	139	250	24	10	160

* Prodotto ADFLEX a richiesta
ADFLEX type on request

BOCCHETTONE
ANGOLARE 90° -
L 425 MM IN
POLIOLEFINE (TPO)

ANGULAR DRAIN 90°
- L 425 MM MADE OF
POLYOLEFENE (TPO)

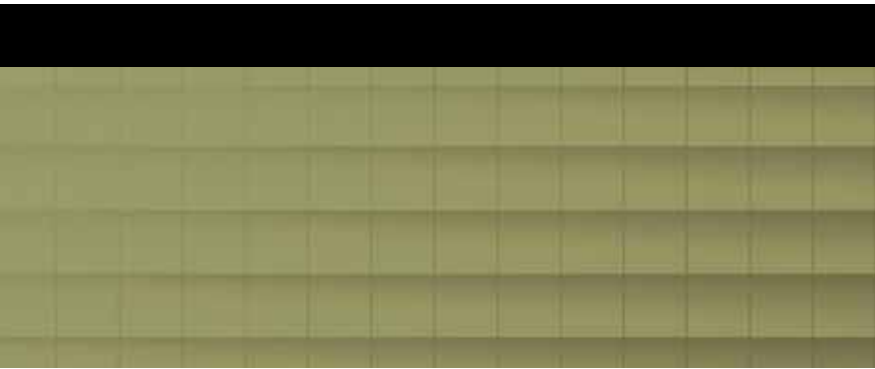

Realizzato in Poliolefine universale di colore bianco, è creato per garantire la massima compatibilità con qualsiasi membrana in Poliolefine. È dotato di raccordi per i tubi di scarico, vedi pagina 50-51.

Manufactured of universal Polyolefine white, they are made to guarantee a perfect compatibility to any sort of TPO waterproofing membrane. See on pages 50-51 for pipe adaptors.

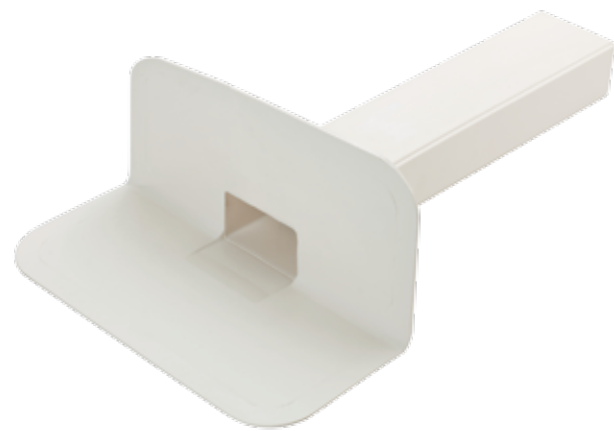
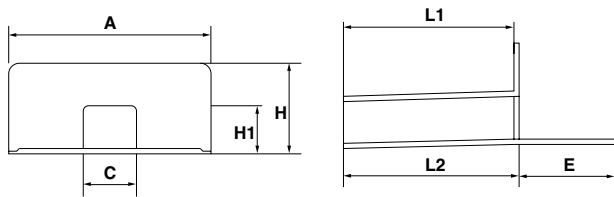

PRODOTTO / PRODUCT												
Codice Code HIFAX	Codice Code ADFLEX*	Tipo Type	A	C	E	H	H1	L1	L2	Pagina listino Price list page		
A042425265	A042425165	100 x 65 - 90°	340	92	145	168	62	425	425	24	8	112

* Prodotto ADFLEX a richiesta
ADFLEX type on request



TPO

ESALATORE IN POLIOLEFINE (TPO) SEMPLICE E DOPPIO - PROTEZIONE CIRCOLARE

TPO

SIMPLE WALL AND DOUBLE WALL POLYOLEFENE ROOF VENT - PROTECTION COLLAR

SSS





Realizzati in Poliolefine universale di colore bianco, questi esalatori sono creati per garantire la massima compatibilità con qualsiasi membrana in Poliolefine. Disponibili in due modelli, il tipo "semplice", che si usa solo in presenza di membrana impermeabile, il tipo "doppio" che si usa nel caso venga applicato un pannello isolante. Raccomandiamo l'utilizzo dell'apposita protezione circolare.

Manufactured of universal Polyolefine white, they are made to guarantee a perfect compatibility to any sort of TPO waterproofing membrane. It is available in the following models: the simple wall version used in case of a simple waterproofing membrane and the double wall version used in the presence of insulating boards. For a further protection, a specific collar is also provided.

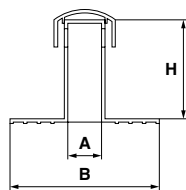





ESALATORE SEMPLICE H 225 MM SIMPLE ROOF VENT H 225 MM

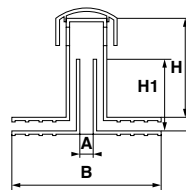

PRODOTTO / PRODUCT										
Codice Code HIFAX	Codice Code ADFLEX*	Tipo Type	Ø esterno Ø external	A	B	H	H1	Pagina listino Price list page	 Pz	 Pz
D401325075	D401225075	Semplice Simple wall	75	72	300	225	-	25	 25	 225

ESALATORE DOPPIO H 225 MM DOUBLE ROOF VENT H 225 MM





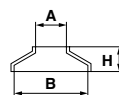

PRODOTTO / PRODUCT										
Codice Code HIFAX	Codice Code ADFLEX*	Tipo Type	Ø esterno Ø external	A	B	H	H1	Pagina listino Price list page	 Pz	 Pz
D410325075	D410225075	Doppio Double wall	75	60	300	225	190	25	 25	 225

* Prodotto ADFLEX a richiesta
ADFLEX type on request

PROTEZIONE CIRCOLARE PROTECTION COLLAR



PRODOTTO / PRODUCT										
Codice Code	Tipo Type	A	B	H	H1	Pagina listino Price list page	 Pz	 Pz		
D150000000	Protezione circolare Protection collar	75	180	60	-	25	 25	 1750		

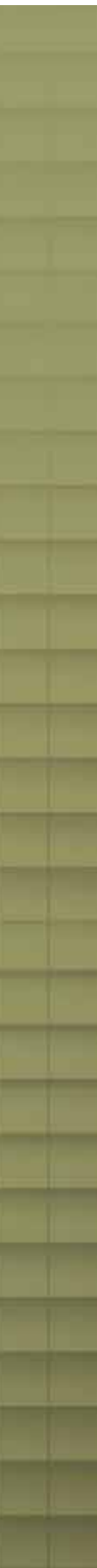

TPO

RACCORDO PER TUBI IN TPO RACCORDO CONICO IN TPO

TPO

TPO BASE FITTING FOR PIPES - TPO CONICAL BASE FITTING FOR PIPES

SSS

I raccordi vengono applicati nei casi in cui fuoriescano dei tubi di sfiato dal solaio di copertura. L'applicazione è molto semplice, basta tagliare in corrispondenza della sezione richiesta, inserirlo all'esterno del tubo e sigillare mediante fascetta metallica stringitubo.

Base fittings are available to solve the problem of ventilation pipes coming out from the roofing floor. The application is very simple. The base fittings shall be cut according to the pipe diameter required and then slipped on to the pipe. A metal ring to squeeze the rubber connection around the pipe will finish the operation.

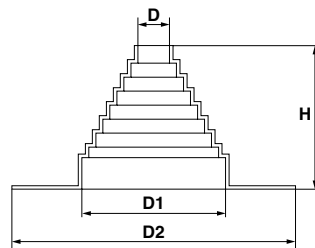

PRODOTTO / PRODUCT

Codice Code HIFAX	Codice Code ADFLEX*	D	D1	D2	H	Pagina listino Price list page	Pz	Pz
F002003010	F002003000	40	175	395	190	26	12	360

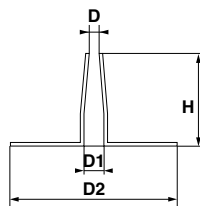

PRODOTTO / PRODUCT

Codice Code HIFAX	Codice Code ADFLEX*	D	D1	D2	H	Pagina listino Price list page	Pz	Pz
F013003002	F013003000	15	30	210	120	26	50	2100

* Prodotto ADFLEX a richiesta
ADFLEX type on request

PROFILI PERIMETRALI PER MEMBRANE IN TPO

PERIMETRAL PROFILES FOR TPO MEMBRANES



I profili perimetrali sono compatibili con qualsiasi membrana impermeabile in Poliolefine (TPO). Sono realizzati in lamiera zincata accoppiata ad una membrana TPO.

This kind of profile is perfectly compatible to any kind of TPO waterproofing membrane. It is manufactured with galvanized-plate combined to a TPO sheet.

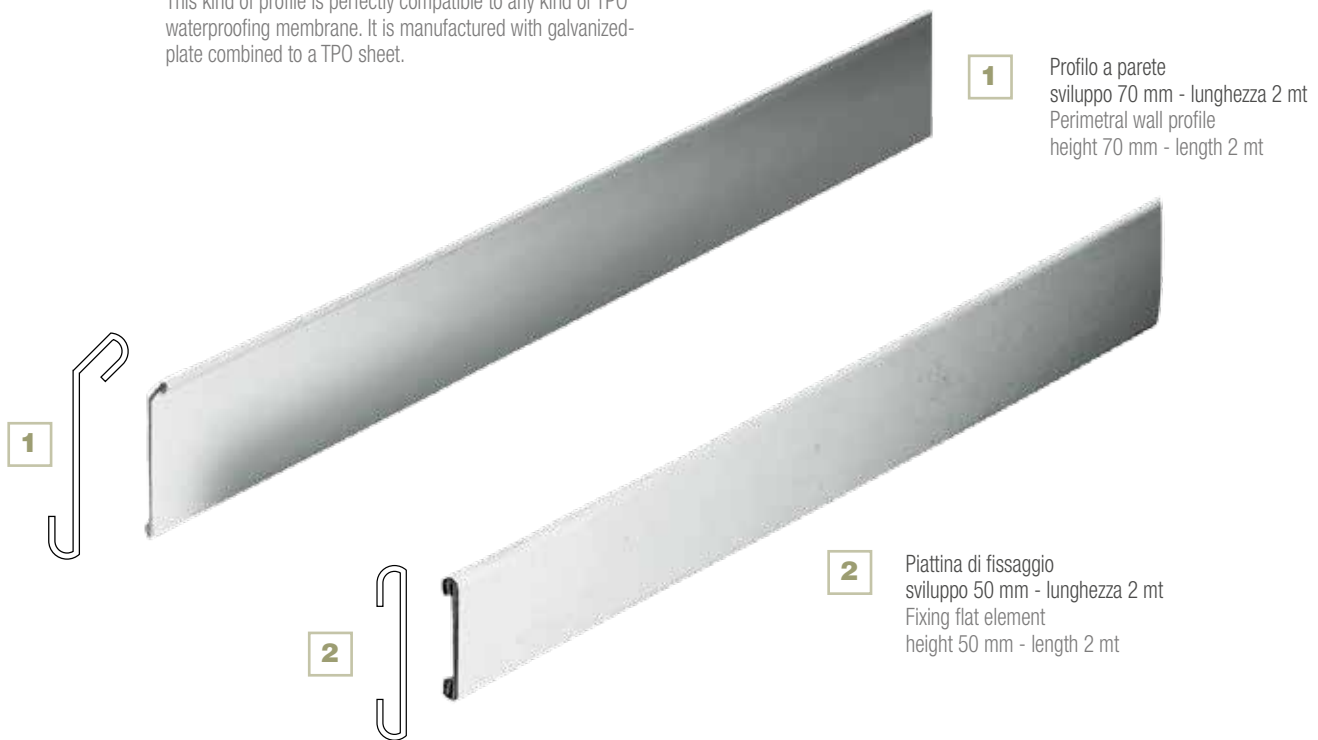

1 Profilo a parete
sviluppo 70 mm - lunghezza 2 mt
Perimetral wall profile
height 70 mm - length 2 mt

2 Piattina di fissaggio
sviluppo 50 mm - lunghezza 2 mt
Fixing flat element
height 50 mm - length 2 mt

PRODOTTO / PRODUCT				
Codice Code	Tipo Type	Pagina listino Price list page	 m	 Pz
F041107002	70 mm	26	2	-
F040105002	50 mm	26	2	-



> POSA IN OPERA
ACCESSORI PER
MANTI SINTETICI
PVC - TPO
> ACCESSORIES
FOR PVC - TPO
LAYERS
INSTALLATION

TPO

ANGOLI INTERNI ED
ESTERNI IN TPO

TPO



TPO INTERNAL AND
EXTERNAL CORNER

SSS

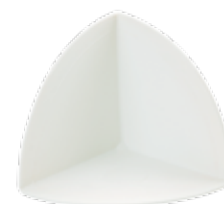
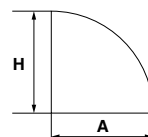

Gli angoli interni ed esterni in TPO sono elementi molto importanti ed indispensabili al completamento di una impermeabilizzazione con membrane poliolefiniche. Servono infatti a proteggere e rinforzare gli spigoli e gli angoli presenti nella copertura da impermeabilizzare per esempio in presenza di muri e lucernari. Sono disponibili nei modelli "Mini", "Medio" e l'esclusiva versione "Maxi" con un'altezza di ben 150 mm per offrire una superficie impermeabilizzante davvero fuori standard.

TPO internal and external corners are element of a high importance and needed to finish a waterproofing with single-ply TPO membranes. The main purpose of these items is to protect and reinforce the waterproofing sheet on corners and edges in presence of walls and skylights. They are available in different types: the brand new "Mini" type, "Medium" and the exclusive "Maxi" type that thanks to its large surface (150mm high) is a unique version that offers a very wide waterproofing area.

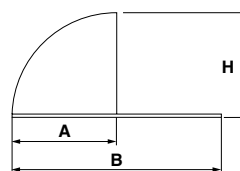

ANGOLO INTERNO "MINI"
INTERNAL CORNER "MINI"

PRODOTTO / PRODUCT							
Codice Code HIFAX	Codice Code ADFLEX*	A	B	H	Pagina listino Price list page		
F011004200	F011004210	70	-	70	27	350	-

ANGOLO ESTERNO "MINI"
EXTERNAL CORNER "MINI"

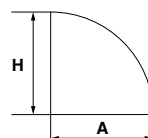
PRODOTTO / PRODUCT							
Codice Code HIFAX	Codice Code ADFLEX*	A	B	H	Pagina listino Price list page		
F010004200	F010004210	67	128	70	27	200	-



ANGOLO INTERNO "MEDIO"
INTERNAL CORNER "MEDIUM"

PRODOTTO / PRODUCT							
Codice Code HIFAX	Codice Code ADFLEX*	A	B	H	Pagina listino Price list page		
F011004020	F011004000	95	-	95	27	200	6000**

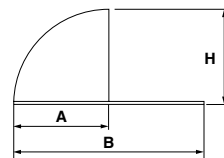
ANGOLO ESTERNO "MEDIO"
EXTERNAL CORNER "MEDIUM"



PRODOTTO / PRODUCT

Codice Code HIFAX	Codice Code ADFLEX*	A	B	H	Pagina listino Price list page	 Pz	 Pz
F010004020	F010004000	93	173	100	27	100	3000**

ANGOLO INTERNO "MAXI"
INTERNAL CORNER "MAXI"

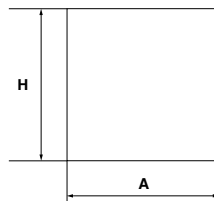



PRODOTTO / PRODUCT

Codice Code HIFAX	Codice Code ADFLEX*	A	B	H	Pagina listino Price list page	 Pz	 Pz
F011004030	F011004040	150	-	150	27	80	1600**

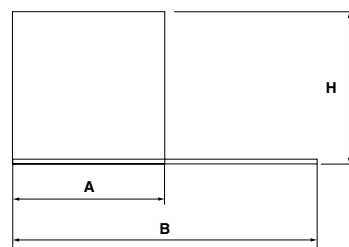
ANGOLO ESTERNO "MAXI"
EXTERNAL CORNER "MAXI"



PRODOTTO / PRODUCT

Codice Code HIFAX	Codice Code ADFLEX*	A	B	H	Pagina listino Price list page	 Pz	 Pz
F010004030	F010004040	150	400	150	27	40	800**

* Prodotto ADFLEX a richiesta
ADFLEX type on request

** Dimensioni pallet mm 1200 x 800 x h 1100
Pallet size mm 1200 x 800 x h 1100

TPE
FLAT

EPDM



BOCCHETTONI "EURO" IN TPE FLAT CON FLANGIA LISCIA E CODOLO H 400 MM

"EURO" TPE FLAT ROOF OUTLET
WITH SMOOTH FLANGE AND
400 MM SPIGOT



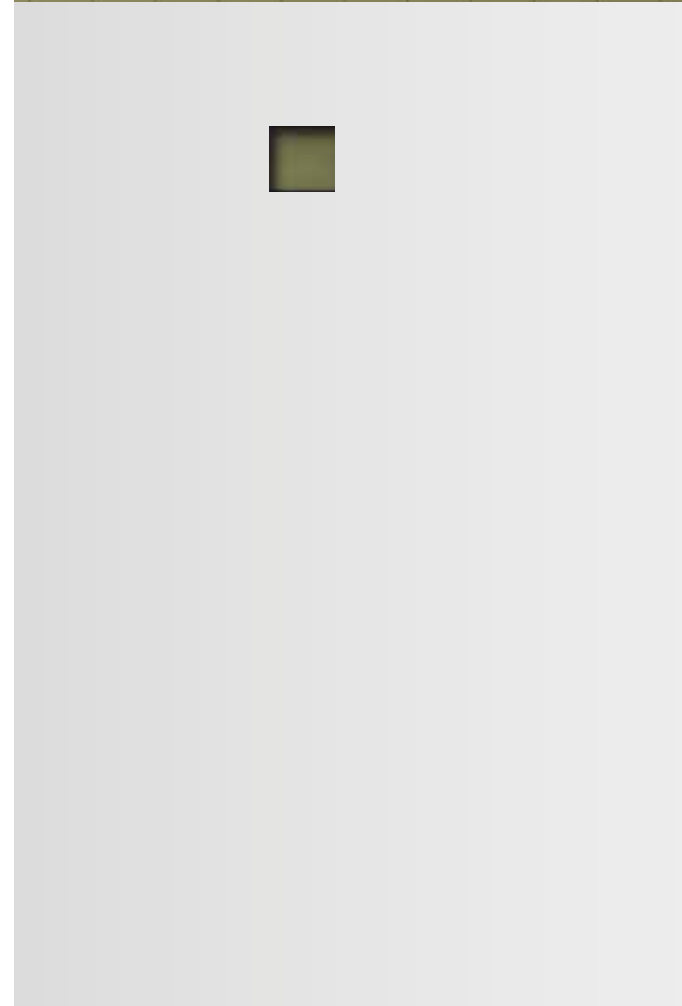
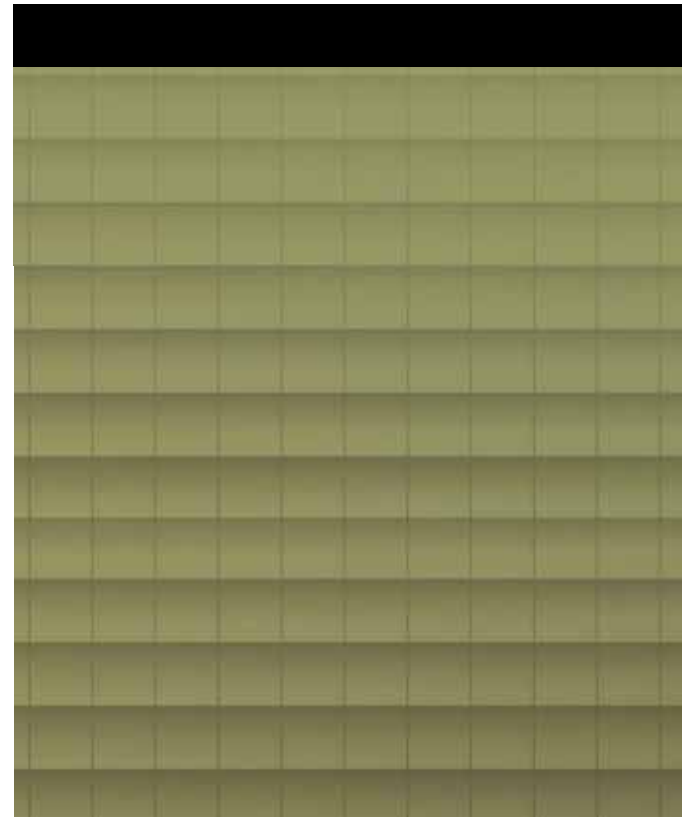

I nuovi bocchettoni in TPE con flangia liscia sono stati appositamente creati per l'applicazione di membrane in EPDM, gomma butilica e similari. Non potendoci essere compatibilità chimica, la flangia liscia funge infatti da supporto ottimale per la stesura di collanti o bande biadesive appositamente sviluppate per l'incollaggio di tali membrane. Il codolo è fornito di una serie di alette antiriflusso che prevengono infiltrazioni in caso di riflusso d'acqua.

The new TPE roof outlets with smooth flange have been properly developed as the ideal solution for the adhesion of synthetic EPDM, butyl rubber and similar waterproofing membranes. Since non chemical welding is possible, the smooth flange offers an ideal laying support for glues or self adhesive bands. The spigot is provided with anti-infiltration tongues to prevent infiltration in case of water back-up.

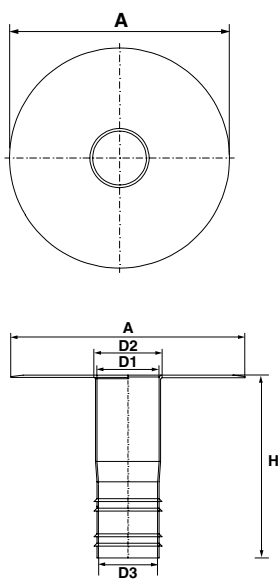
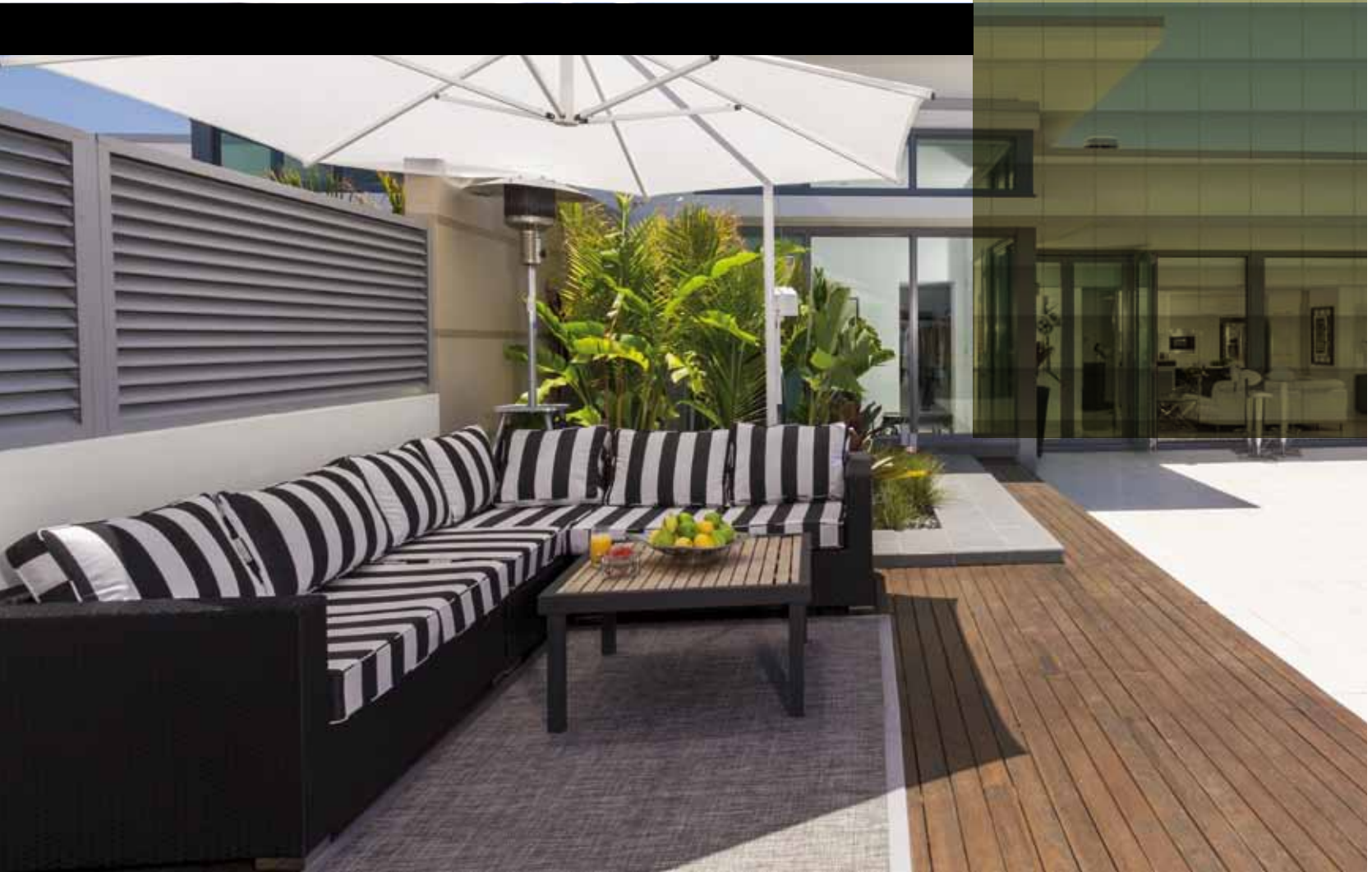



PRODOTTO / PRODUCT									
Codice Code	Per tubi For pipes	A	D1	D2	D3	H	Pagina listino Price list page		
A013041063	Ø 63	320	51	60	49	400	28	15	240
A013041075	Ø 75	320	63	70	62	400	28	15	240
A013041082	Ø 82	320	69	75	68	400	28	15	240
A013041090	Ø 90	320	80	84	79	400	28	15	240
A013041100	Ø 100	320	86	90	85	400	28	15	240
A013041110	Ø 110	380	95	101	94	400	28	12	192
A013041125	Ø 125	380	109	115	108	400	28	12	96
A013041140	Ø 140	380	128	134	127	400	28	10	80
A013041150	Ø 150	380	134	140	132	400	28	10	80
A013041160	Ø 160	380	140	146	139	400	28	10	80

TPE
FLAT

EPDM



BOCCHETTONI ANGOLARI IN TPE FLAT CON FLANGIA LISCIA

TPE FLAT ANGULAR DRAIN OUTLET WITH SMOOTH FLANGE



Come per la versione verticale, anche la nuova gamma di bocchettoni a scarico laterale in TPE con flangia liscia sono stati creati per l'applicazione di membrane sintetiche in EPDM, gomma butilica e similari. Il codolo orizzontale è disponibile in diverse misure con sezione quadrata, rettangolare o tonda.

As for the vertical version, the new range of TPE angular outlets with smooth flange has been created as ideal solution for a perfect adhesion of synthetic EPDM, butyl rubber and similar waterproofing membranes. The exit spigot is available in different sizes and squared, rectangular or round sections.

SEZIONE 100 X 100 MM 100 X 100 MM SECTION

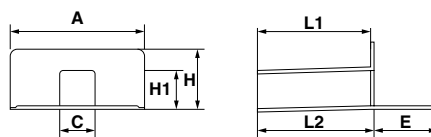

PRODOTTO / PRODUCT

Codice Code	Tipo Type	A	C	E	H	H1	L1	L2	Pagina listino Price list page	Pz	Pz
A041375012	90°	340	92	145	168	92	375	375	29	5	80

RACCORDO SEZIONE 100 X 100 MM PIPE ADAPTOR 100 X 100 MM SECTION

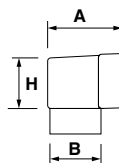

PRODOTTO / PRODUCT

Codice Code	Misura Size	A	B	H	Pagina listino Price list page	Pz	Pz
F071080010	Ø 80	148	78	95	29	10	700
F071100010	Ø 100	148	96	96	29	10	700

RACCORDO SEZIONE 100 X 65 MM PIPE ADAPTOR 100 X 65 MM SECTION

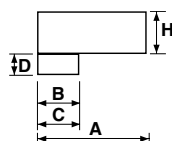



PRODOTTO / PRODUCT

Codice Code	Misura Size	A	B	C	D	H	Pagina listino Price list page	Pz	Pz
F072063080	Ø 63 - 80	218	63	80	45	65	29	10	360
F072080100	Ø 80 - 100	218	80	100	62	65	29	10	360

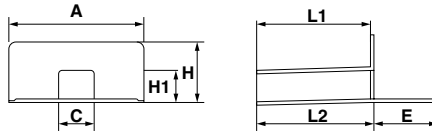

SEZIONE 100 X 65 MM
100 X 65 MM SECTION



PRODOTTO / PRODUCT											
Codice Code	Tipo Type	A	C	E	H	H1	L1	L2	Pagina listino Price list page		
A042425066	90°	340	92	145	168	62	425	425	29	10	140

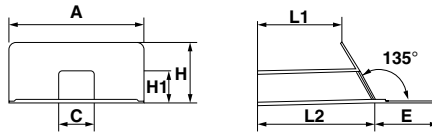

SEZIONE 100 X 65 MM
100 X 65 MM SECTION

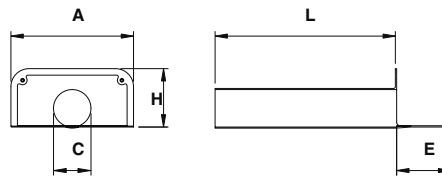

PRODOTTO / PRODUCT											
Codice Code	Tipo Type	A	C	E	H	H1	L1	L2	Pagina listino Price list page		
A040425066	135°	340	95	145	115	62	340	425	29	10	140

BOCCHETTONE ANGOLARE
USCITA TONDA FLANGIA LISCIA
ANGULAR DRAIN WITH ROUND
SPIGOT SMOOTH FLANGE



PRODOTTO / PRODUCT										
Codice Code	Per tubi For pipes	A	C	E	H	L	Pagina listino Price list page			
A045501063	Ø 63	340	63	150	133	500	30	8	80	
A045501075	Ø 75	340	75	150	133	500	30	8	80	
A045501080	Ø 80	340	80	150	165	500	30	8	80	
A045501090	Ø 90	340	90	150	165	500	30	8	80	
A045501100	Ø 100	340	100	150	165	500	30	8	80	
A045501110	Ø 110	340	110	150	165	500	30	8	80	
A045501125	Ø 125	340	125	150	165	500	30	7	70	

TPE
FLAT

EPDM

ESALATORE IN TPE FLAT CON FLANGIA
LISCIA - PROTEZIONE CIRCOLARETPE FLAT ROOF VENT PIPES WITH
SMOOTH FLANGE - PROTECTION COLLAR

La nuova gamma di esalatori in TPE con flangia liscia è stata anch'essa creata per l'applicazione di membrane sintetiche in EPDM, gomma butilica e similare. Sono disponibili nei modelli tipo "semplice", che si usa in presenza della sola membrana impermeabile ed il tipo "doppio" che si usa in presenza di un pannello isolante. Raccomandiamo l'uso dell'apposita protezione circolare.

The new range of TPE roof air vents with smooth flange has been also created as ideal solution for a perfect adhesion of synthetic EPDM, butyl rubber and similar waterproofing membranes. As usually they are available in the following models: the simple wall version used in case of a simple waterproofing membrane and the double wall version used in the presence of any insulation. For a further protection, a specific collar is also provided.

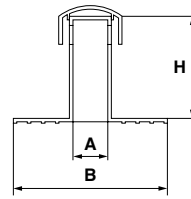
ESALATORE SEMPLICE H 225 MM
SIMPLE ROOF VENT H 225 MM

PRODOTTO / PRODUCT									
Codice Code	Tipo Type	Ø esterno Ø external	A	B	H	H1	Pagina listino Price list page	Pz	Pz
D020225075	Semplice Simple wall	75	72	300	225	-	31	25	225

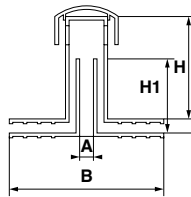
ESALATORE DOPPIO H 225 MM
DOUBLE ROOF VENT H 225 MM

PRODOTTO / PRODUCT									
Codice Code	Tipo Type	Ø esterno Ø external	A	B	H	H1	Pagina listino Price list page	Pz	Pz
D036225075	Doppio Double wall	75	60	300	225	190	31	25	225

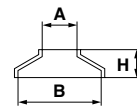
PROTEZIONE CIRCOLARE
PROTECTION COLLAR

PRODOTTO / PRODUCT									
Codice Code	Tipo Type	A	B	H	Pagina listino Price list page	Pz	Pz		
D150000000	Protezione circolare Protection collar	75	180	60	31	25	1750		

- RACCORDO PER TUBI IN TPE FLAT
- RACCORDO CONICO IN TPE FLAT
- TPE FLAT PIPES PROTECTION
- TPE BASE FITTING WITH SMOOTH FLANGE



I raccordi vengono applicati nei casi in cui fuoriescano dei tubi di sfiato dal solaio di copertura. L'applicazione è molto semplice, basta tagliare in corrispondenza della sezione richiesta, inserirlo all'esterno del tubo e sigillare mediante fascetta metallica stringitubo.

Base fittings are available to solve the problem of ventilation pipes coming out through the roofing floor. The application is very simple. The base fittings shall be cut according to the pipe diameter required and then slipped on to the pipe. A metal ring to squeeze the rubber connection around the pipe will finish the operation.

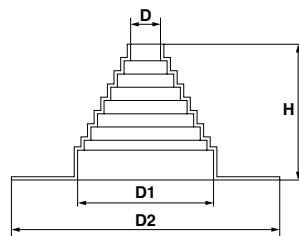

PRODOTTO / PRODUCT								
Codice Code	Tipo Type	D	D1	D2	H	Pagina listino Price list page	Pz	Pz
F001000100	TPE	40	175	395	190	31	12	360

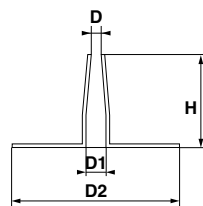

PRODOTTO / PRODUCT								
Codice Code	Tipo Type	D	D1	D2	H	Pagina listino Price list page	Pz	Pz
F013000000	TPE	15	30	210	120	31	50	2100

TPE
FLATANGOLI IN
TPE FLAT

EPDM

TPE FLAT
CORNERS

Servono per rinforzare gli spigoli e gli angoli delle coperture impermeabilizzate.

The main purpose of these items is to reinforce the waterproofing sheet on corners and edges.

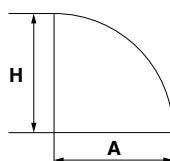

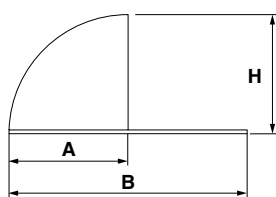

PRODOTTO / PRODUCT

Codice Code	Tipo Type	A	B	H	Pagina listino Price list page	 Pz	 Pz
F011001100	Angolo interno "Medio" Internal corner "Medium"	95	-	95	32	200	6000*



PRODOTTO / PRODUCT

Codice Code	Tipo Type	A	B	H	Pagina listino Price list page	 Pz	 Pz
F010001100	Angolo esterno "Medio" External corner "Medium"	95	175	100	32	100	3000*

* Dimensioni pallet: mm 1200 x 800 x h 1100 / Pallet size: mm 1200 x 800 x h 1100

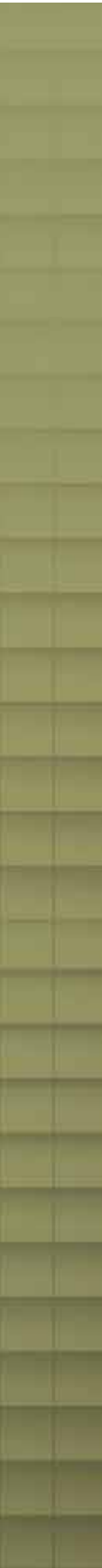
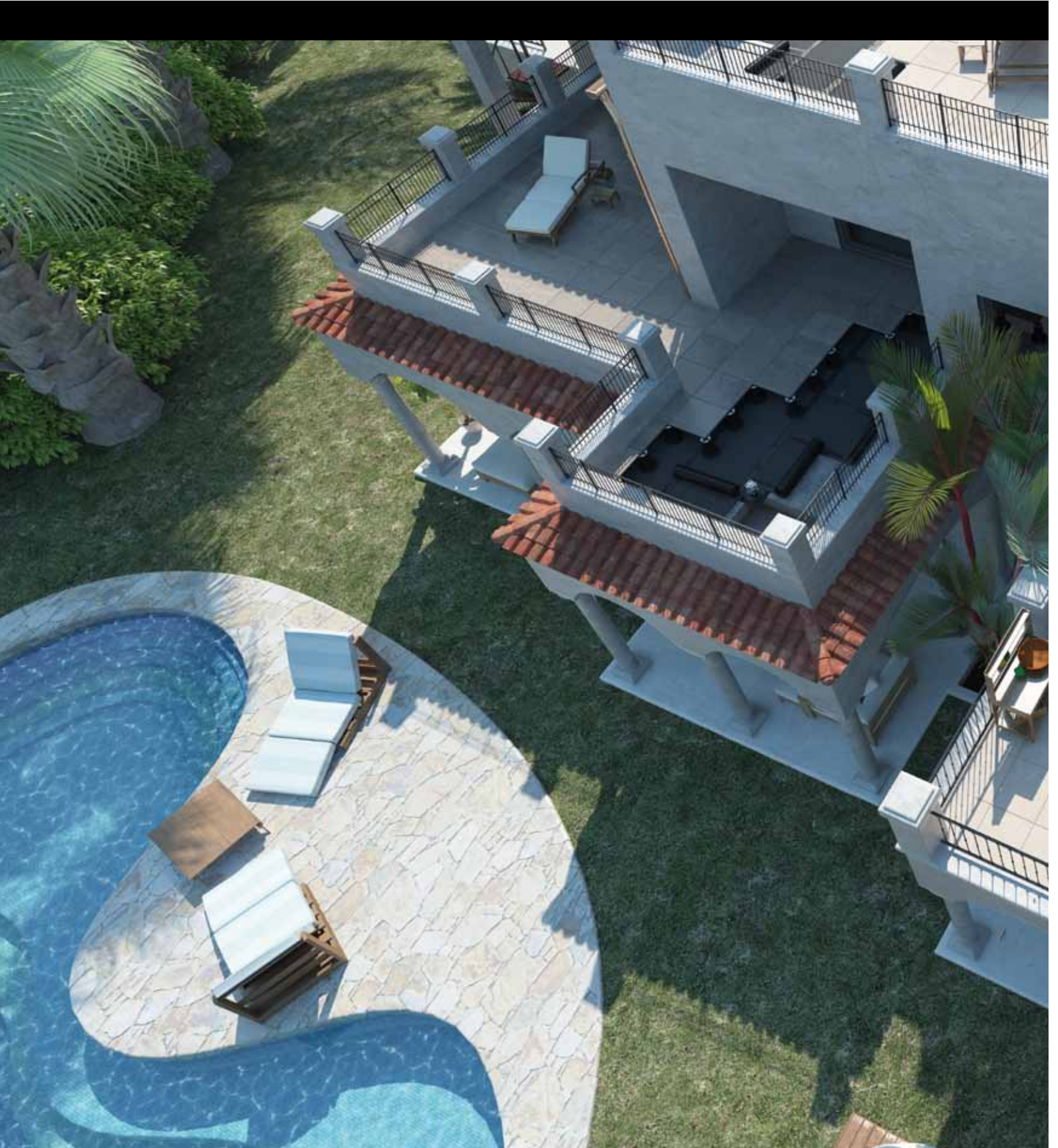



BOCCHETTONI "EURO" IN ECB CON CODOLO H 250 MM

"EURO" ROOF DRAIN
MADE OF ECB WITH A
250 MM SPIGOT

Realizzati in ECB per garantire la compatibilità con qualsiasi tipo di membrana impermeabile in ECB e bituminoso in SBS. La flangia è liscia, in modo da consentire una perfetta fusione con la membrana impermeabile. Il codolo è dotato di due coppie di alette antiriflusso.

Manufactured in ECB to guarantee a perfect compatibility to any sort of ECB waterproofing single-ply and SBS bituminous membrane. The flange is totally smooth for a perfect bonding to the waterproofing membrane. The spigot is provided with two couples of anti-infiltration tongues.

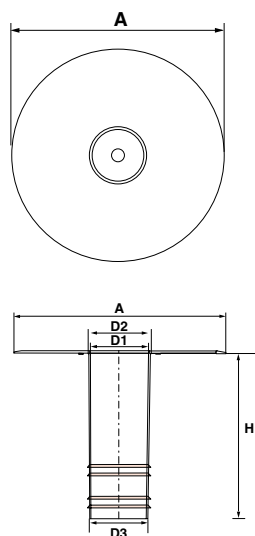

PRODOTTO / PRODUCT									
Codice Code	Per tubi For pipes	A	D1	D2	D3	H	Pagina listino Price list page	Pz	Pz
A013325075	Ø 75	320	63	70	62	250	32	15	240
A013325082	Ø 82	320	69	75	68	250	32	15	240
A013325100	Ø 100	320	86	90	85	250	32	15	240
A013325110	Ø 110	380	95	101	94	250	32	15	240
A013325125	Ø 125	380	109	115	108	250	32	15	240

NB: Su richiesta, qualsiasi articolo in PVC può essere fornito anche in ECB. Quantità minime da rispettare
 NB: On request, any PVC item can be manufactured in EBC too. Minimum quantities to be matched.

BOCCHETTONE ANGOLARE L 425 MM SEZIONE 100 X 65 MM IN ECB - BOCCHETTONE ANGOLARE IN ECB CON CODOLO TONDO

ANGULAR DRAIN L 425 MM SECTION 100 X 65 MM MADE OF ECB - ANGULAR DRAIN MADE OF ECB WITH ROUND SPIGOT

Realizzati in ECB per garantire la compatibilità con qualsiasi membrana impermeabile in ECB e bituminosa in SBS.
La flangia è liscia, in modo da consentire una perfetta fusione con la membrana impermeabile.
La versione 100x65 mm è dotata di raccordi per i tubi di scarico, vedi a pag. 73.

Manufactured in ECB to guarantee a perfect compatibility to any sort of ECB waterproofing single-ply and SBS bituminous membrane.
The flange is totally smooth for a perfect bonding between the roof drain and the waterproofing membrane.
See on page 73 for pipe adaptors for 100 x 65 mm version.



SEZIONE 100 X 65 MM
100 X 65 MM SECTION

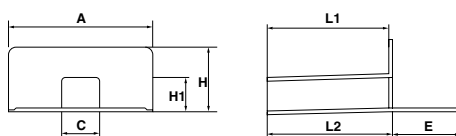

PRODOTTO / PRODUCT											
Codice Code	Tipo Type	A	C	E	H	H1	L1	L2	Pagina listino Price list page	Pz	Pz
A042425365	90°	340	92	145	168	62	425	425	32	8	112

SEZIONE 100 X 65 MM
100 X 65 MM SECTION

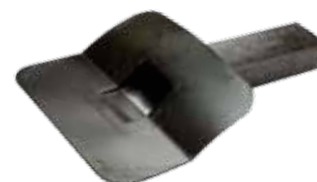
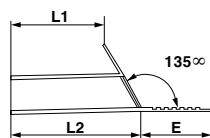

PRODOTTO / PRODUCT											
Codice Code	Tipo Type	A	C	E	H	H1	L1	L2	Pagina listino Price list page	Pz	Pz
A040425365	135°	340	95	145	115	62	340	425	32	8	112

BOCCHETTONE ANGOLARE IN ECB CON CODOLO TONDO
ANGULAR DRAIN MADE OF ECB WITH ROUND SPIGOT

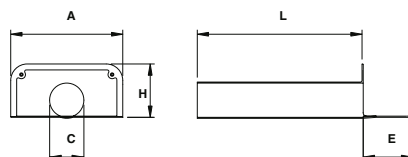

PRODOTTO / PRODUCT										
Codice Code	Tipo Type	A	C	E	H	L	Pagina listino Price list page	Pz	Pz	
A049500063	Ø 63	340	63	150	133	500	33	8	80	
A049500075	Ø 75	340	75	150	133	500	33	8	80	
A049500090	Ø 90	340	90	150	165	500	33	8	80	
A049500110	Ø 110	340	110	150	165	500	33	8	80	
A049500125	Ø 125	340	125	150	185	500	33	7	70	



ESALATORE IN
ECB - PROTEZIONE
CIRCOLARE



WALL ECB ROOF
VENT PIPE -
PROTECTION
COLLAR



Realizzati in ECB per garantire la compatibilità con qualsiasi tipo di membrana in ECB e bituminoso in SBS. È realizzato in due modelli: il tipo "semplice", che si usa in presenza della sola membrana impermeabile ed il tipo "doppio" che si usa in presenza di un pannello isolante. Raccomandiamo l'utilizzo dell'apposita protezione circolare.

Manufactured in ECB to guarantee a perfect compatibility to any sort of ECB waterproofing single-ply and SBS bituminous membrane, it is available in the following models: the simple wall version used in case of a simple waterproofing membrane and the double wall version used in the presence of insulating boards. For a further protection, a proper collar is provided and recommended.

SEMPLICE H 225 - Ø 75 MM
SIMPLE H 225 - Ø 75 MM

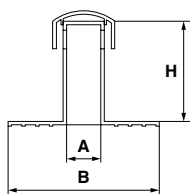

PRODOTTO / PRODUCT

Codice Code	Tipo Type	Ø esterno Ø external	A	B	H	Pagina listino Price list page		
D018225075	Semplice Simple wall	75	72	300	225	33	25	225

DOPPIO H 225 - Ø 75 MM
DOUBLE H 225 - Ø 75 MM

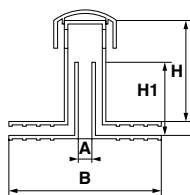

PRODOTTO / PRODUCT

Codice Code	Tipo Type	Ø esterno Ø external	A	B	H	H1	Pagina listino Price list page		
D034225075	Doppio Double wall	75	60	300	225	190	33	25	225

PROTEZIONE CIRCOLARE
PROTECTION COLLAR

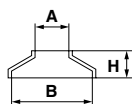

PRODOTTO / PRODUCT

Codice Code	Tipo Type	A	B	H	Pagina listino Price list page		
D150000000	Protezione circolare Protection collar	75	180	60	33	25	1750

RACCORDO PER TUBI IN ECB RACCORDO CONICO IN ECB

ECB

ECB
SBS





ECB CONICAL BASE FITTING FOR PIPES

I raccordi per tubi sono elementi molto utili per impermeabilizzare qualsiasi tipologia di tubo che fuoriesca attraverso il solaio di copertura.

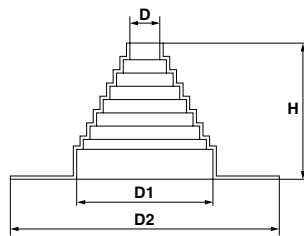
Base fittings are useful elements to waterproof different sorts of pipes coming out through the roofing floor.



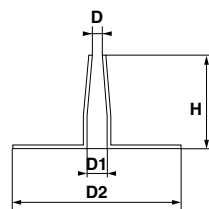

PRODOTTO / PRODUCT

Codice Code	Tipo Type	D	D1	D2	H	Pagina listino Price list page	 Pz	 Pz
F002002000	Raccordo per tubi Base fittings for pipe	40	175	395	190	34	12	360



PRODOTTO / PRODUCT

Codice Code	Tipo Type	D	D1	D2	H	Pagina listino Price list page	 Pz	 Pz
F013002000	Raccordo conico Conical base fitting	15	30	210	120	34	50	2100



ANGOLI "MEDI" E "MAXI" IN ECB

ECB "MEDIUM" AND "MAXI" CORNERS



Gli angoli "Medi" e gli angoli "Maxi" si differenziano tra loro solo per le dimensioni. Sono entrambi disponibili nei modelli "Interno" ed "Esterno" e sono molto utili per rinforzare gli angoli e gli spigoli nelle coperture impermeabilizzate.

"Medium" and "Maxi" corners are simply different each other in sizes, offering a different covering surface. Both are available in the "Internal" and "External" versions and are very useful to reinforce the waterproofing sheet on corners and edges.

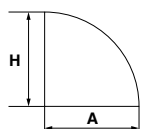

PRODOTTO / PRODUCT							
Codice Code	Tipo Type	A	B	H	Pagina listino Price list page	Pz	Pz
F011002101	Angolo interno "Medio" Internal corner "Medium"	95	-	95	34	200	6000*

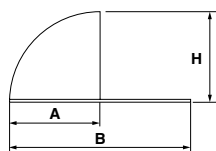

PRODOTTO / PRODUCT							
Codice Code	Tipo Type	A	B	H	Pagina listino Price list page	Pz	Pz
F010002101	Angolo esterno "Medio" External corner "Medium"	93	173	100	34	100	3000*

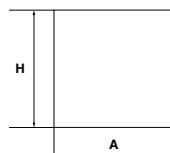

PRODOTTO / PRODUCT							
Codice Code	Tipo Type	A	B	H	Pagina listino Price list page	Pz	Pz
F011002010	Angolo interno "Maxi" Internal corner "Maxi"	150	-	150	34	80	1280*

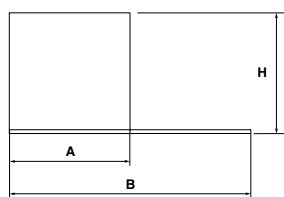
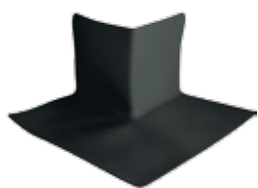

PRODOTTO / PRODUCT							
Codice Code	Tipo Type	A	B	H	Pagina listino Price list page	Pz	Pz
F010002010	Angolo esterno "Maxi" External corner "Maxi"	150	400	150	34	40	640*

* Dimensioni pallet: mm 1200 x 800 x h 1100 / Pallet size: mm 1200 x 800 x h 1100

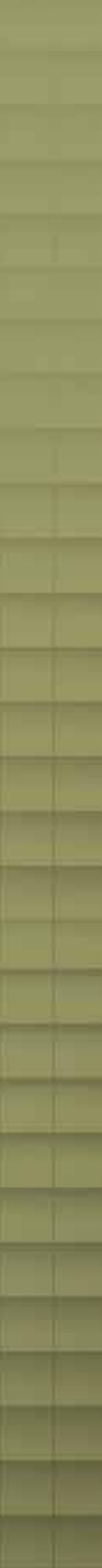
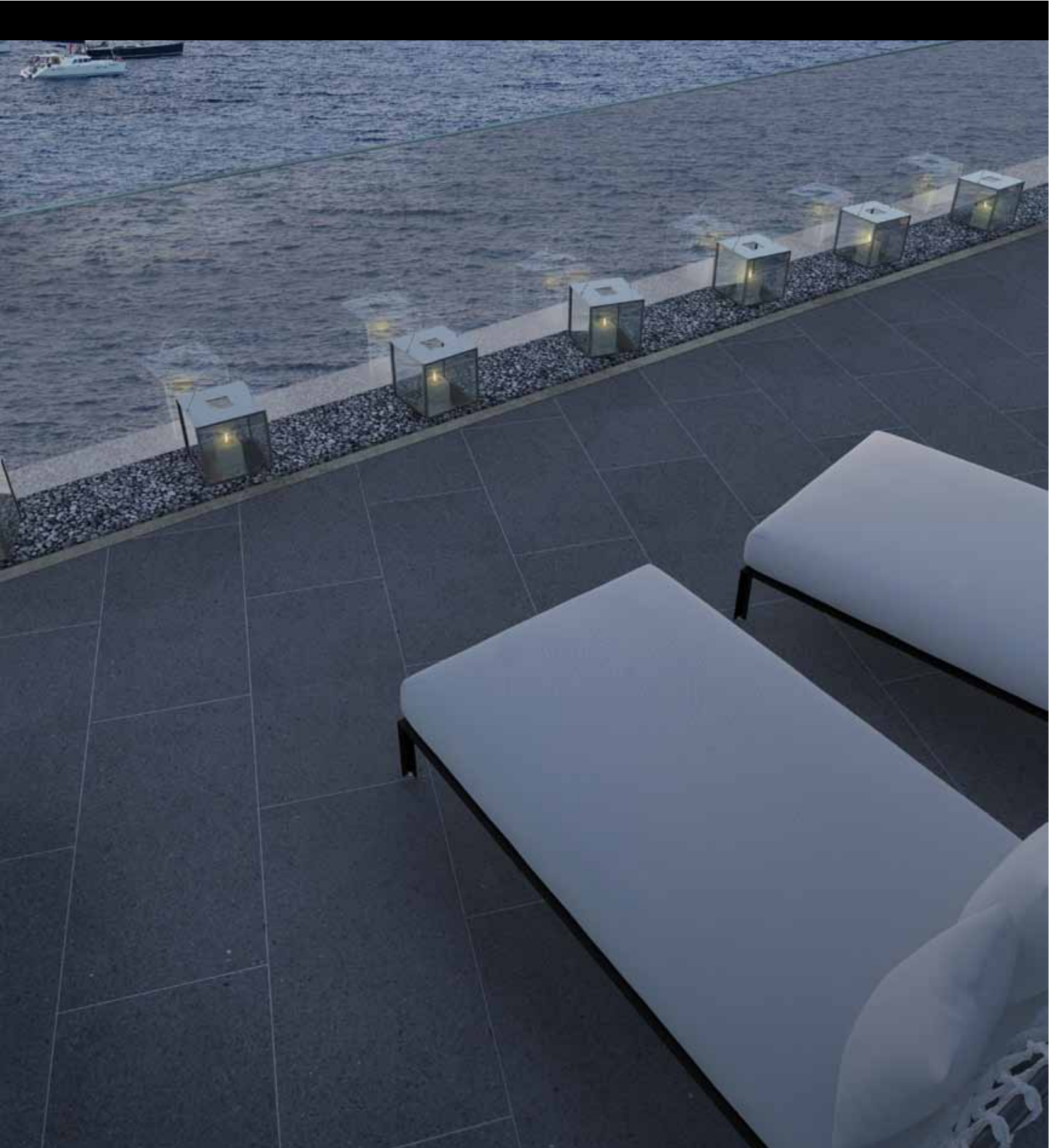

PARAFOGLIE

LEAF-GUARDS



PER BOCCHETTONI
DI SCARICO Ø DA
60 A 120 MM

FOR Ø 60 MM TO
Ø 120 MM DRAIN
OUTLETS

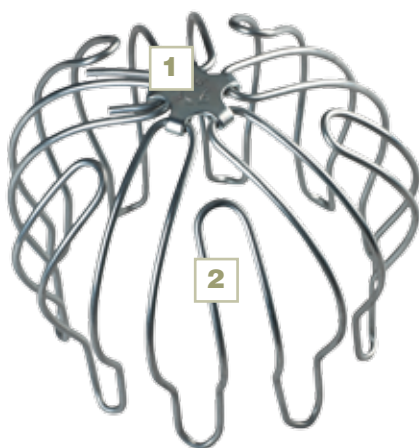

- 1** Borchia stringifilo senza saldature
Weldless wire escutcheon
- 2** Unico filo di zinco (Ø 2,7 mm)
senza saldature
Single weldless zinc wire
(Ø 2.7 mm)

PER BOCCHETTONI
DI SCARICO Ø DA
60 A 140 MM

FOR Ø 60 MM TO
Ø 140 MM DRAIN
OUTLETS



- 1** Anello di rinforzo
Reinforcement ring
- 2** Unico elemento in PP
Single element in PP
- 3** Speciale grip per
inserimento nei
bocchettoni di scarico
Special grip for insertion
into the drain outlets



VERSIONI
TYPES

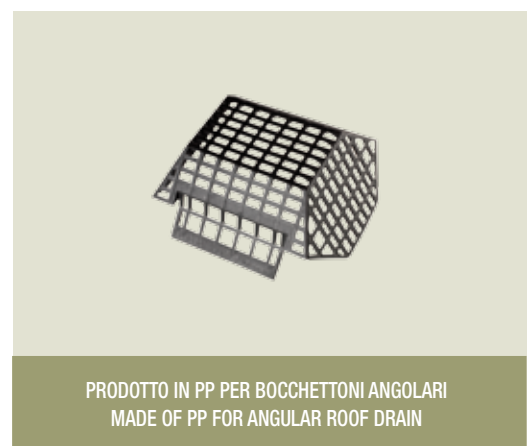
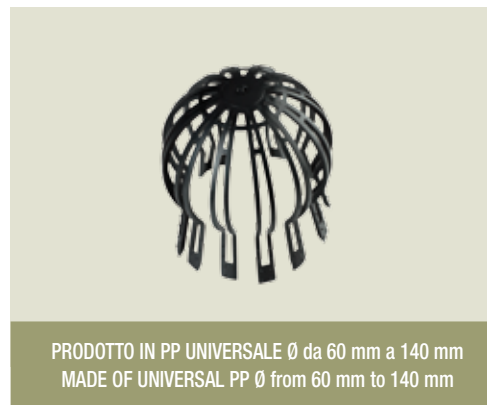
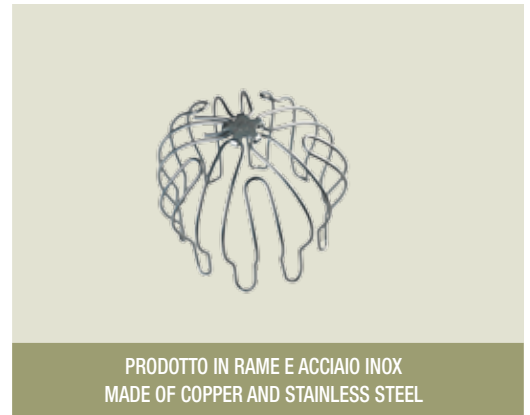



PARAFOGLIE UNIVERSALI IN PP, ZINCO, RAME, ACCIAIO INOX E PER BOCCHETTONE ANGOLARE 45°

PP, ZINC, COPPER AND STAINLESS STEEL LEAF-GUARDS AND PP LEAF-GUARD FOR 45° ANGULAR DRAIN

Per proteggere le condotte di scarico da foglie e sporcizia in genere, raccomandiamo di applicare la parafoglia al bocchettone. La gamma "Eterno" offre più di una possibilità: una parafoglia in PP a misura fissa, da Ø 60 a 200 mm, una parafoglia in PP a misura variabile da Ø 60 a 140 mm, una parafoglia metallica in zinco, rame o acciaio inox a misura variabile da Ø 60 a 120 mm, una parafoglia specifica per bocchettoni angolari a 45°.

To protect the drain-pipe from leaves and dirt, we always recommend to install a leaf-guard on the roof drain. The "Eterno" range offers leaf-guards made of PP with fixed size from 60 to 200 mm diameter, a PP leafguard with variable size from 60 to 140 mm diameter, metallic leafguards made of zinc, copper and stainless steel with variable size from Ø 60 to Ø 120 mm, and a specific PP leaf-guard for angular drains with a 45° corner.

PARAFOGLIA PP A MISURA FISSA FIXED SIZE PP LEAF-GUARD

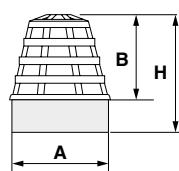



Individua il diametro del tuo bocchettone e scegli il parafoglia corrispondente.
Match the diameter of your drain and choose the right leaf guard.

PRODOTTO / PRODUCT							
Codice Code	Ø	A	B	H	Pagina listino Price list page		Pz
C001000060	60	47	54	84	35	25	1750
C001000075	75	62	75	105	35	25	1750
C001000080	80	68	70	100	35	25	1750
C001001080	80L	68	70	100	35	25	1750
C001000090	90	78	70	100	35	25	1750
C001000100	100	88	70	100	35	25	1750
C001000110	110	92	70	100	35	25	1750
C001000120	120	100	70	100	35	25	1750
C001001120	120L	100	70	100	35	25	1750
C001000125	125	109	70	100	35	20	1400
C001000140	140	125	70	100	35	20	1400
C001000150	150	130	70	100	35	15	1050
C001000160	160	143	75	105	35	15	1050
C001000200	200	177	75	105	35	10	700

"Eterno" H 200 Ø	"Eterno" H 500 Ø	"Mondial" Ø	"Euro"/"Genius" Ø
50 - 60		60	
75			
80		80	90
			82
90	80		100
100		100	
110			110
120		120	125
	100		
125			
140	120		140
150		150	150
160	150		
200			

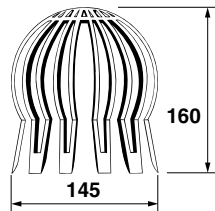
PARAFOGLIA
UNIVERSALE IN PP
FLEXIBLE PP
LEAF-GUARD



PRODOTTO / PRODUCT					
Codice Code	Misura Size	Tipo Type	Pagina listino Price list page	 Pz	 Pz
C005000000	60 ÷ 140	Special PP	36	100	2000
C005000001	60 ÷ 140	"Standard" PP	36	100	2000

PARAFOGLIA
UNIVERSALE IN ZINCO,
RAME, ACCIAIO
FLEXIBLE ZINC, COPPER,
STAINLESS STEEL
LEAF-GUARD

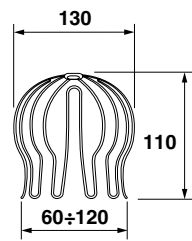

PRODOTTO / PRODUCT					
Codice Code	Misura Size	Tipo Type	Pagina listino Price list page	 Pz	 Pz
C002000000	60 ÷ 120	Zinco Zinc	36	50	3600
C003000000	60 ÷ 120	Rame Copper	36	50	3600
C004000000	60 ÷ 120	Acciaio Inox Stainless steel	36	50	3600

PARAFOGLIA
ANGOLARE
LEAF-GUARD FOR
ANGULAR DRAIN

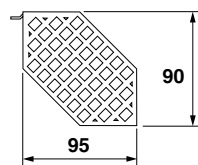

PRODOTTO / PRODUCT					
Codice Code	Misura Size	Tipo Type	Pagina listino Price list page	 Pz	 Pz
C020000045	Per bocchettone angolare 45° For 45° angular drain		36	20	1400



PARAGHIAIA -
PROLUNGA PER
PARAGHIAIA ASTA
UNIVERSALE

GRAVEL-GUARD
- EXTENSION
RING - UNIVERSAL
ADAPTOR

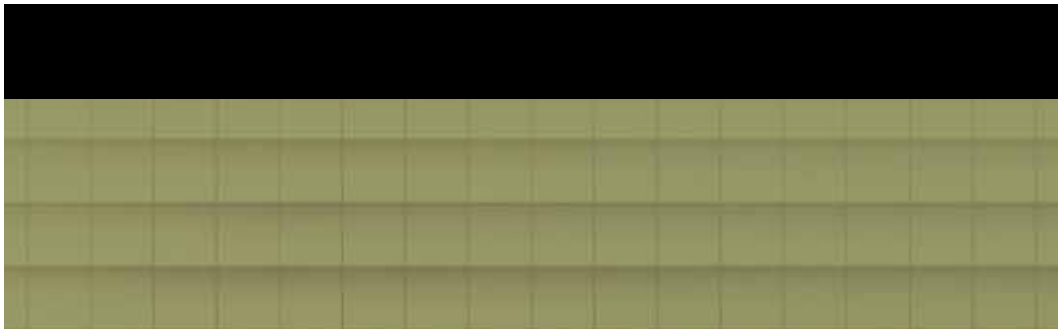

PARAGHIAIA
GRAVEL-GUARD

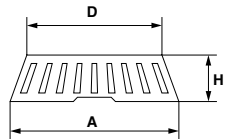

PRODOTTO / PRODUCT

Codice Code	A	D	H	Pagina listino Price list page	Pz	Pz
C023000000	195	170	50	37	50	1000

PROLUNGA
EXTENSION RING

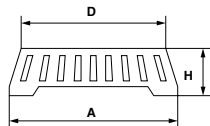

PRODOTTO / PRODUCT

Codice Code	A	D	H	Pagina listino Price list page	Pz	Pz
C024000000	215	195	170	37	50	1000

ASTA UNIVERSALE
UNIVERSAL ADAPTER

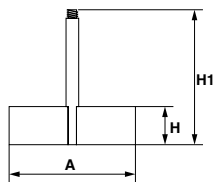

PRODOTTO / PRODUCT

Codice Code	A	H	H1	Pagina listino Price list page	Pz	Pz
C025000000	130	40	150	37	50	3500

PARAGHIAIA MODELLO SPAGNA
GRAVEL-GUARD SPAIN VERSION

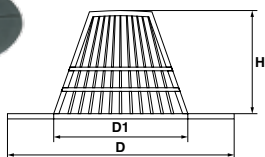

PRODOTTO / PRODUCT

Codice Code	D	D1	H	Pagina listino Price list page	Pz	Pz
C027000000	335	198	150	37	25	500



RETE PROTEGGI-GRONDE
EAVES GUTTER-GUARD

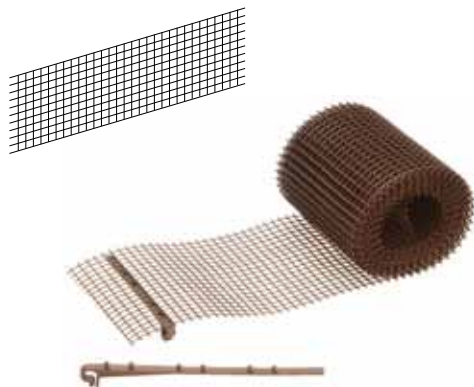

PRODOTTO / PRODUCT					
Codice Code	Misura Size	Colore Colour	Pagina listino Price list page	 Pz	 Pz
F128002618	mt 6 x cm 18	Marrone Brown	37	12	300
F128002624	mt 6 x cm 24	Marrone Brown	37	10	250

SALVASPORGENZE

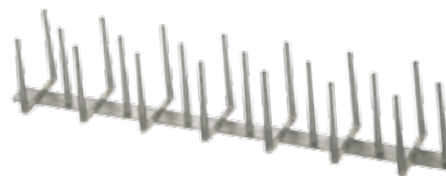
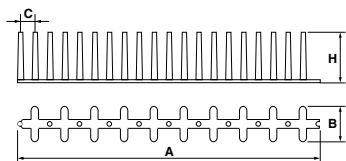

EAVE-COMB FILLER

SALVASPORGENZE
IN PP
POLYPROPYLENE
EAVE COMB FILLER



PP

PRODOTTO / PRODUCT

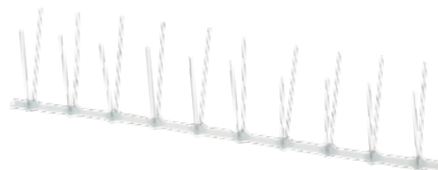
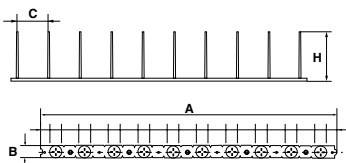

Codice Code	Tipo Type	A	B	C	H	Pagina listino Price list page	 m	 Pz
F122008333	Neutro Neutral	500	55	25	80	38	100	800

SALVASPORGENZE
METALLICO "STANDARD"
"STANDARD" METAL
EAVE COMB FILLER



INOX

PRODOTTO / PRODUCT

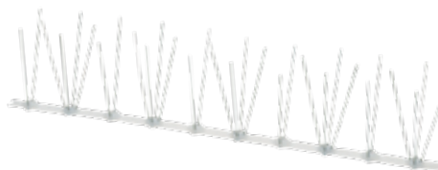
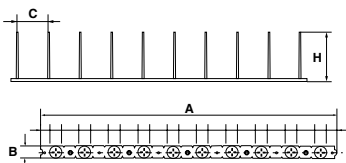

Codice Code	A	B	C	H	Pagina listino Price list page	 m	 Pz
F123011050	500	20	50	110	38	50	2000

SALVASPORGENZE
METALLICO "SPECIAL"
"SPECIAL" METAL EAVE
COMB FILLER



INOX

PRODOTTO / PRODUCT

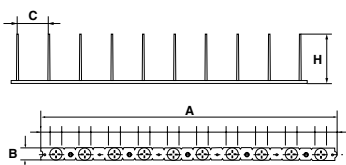

Codice Code	A	B	C	H	Pagina listino Price list page	 m	 Pz
F124011050	20	50	110	25	38	25	1000

SALVASPORGENZE
METALLICO "INOX"
"INOX" METAL
EAVE COMB FILLER



INOX

PRODOTTO / PRODUCT

Codice Code	A	B	C	H	Pagina listino Price list page	 m	 Pz
F125000000	1000	20	50	110	38	25	450

PETTINI ANTINIDO

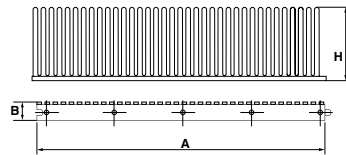

ANTI-NEST COMB

PETTINE ANTINIDO IN PP PP ANTI-NEST COMB



PP

PRODOTTO / PRODUCT

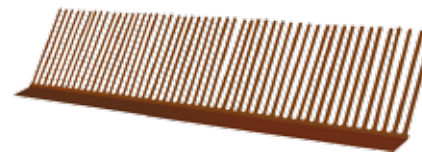
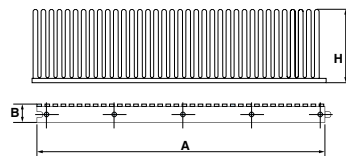

Codice Code	Tipo Type	Colore Colour	A	B	H	Pagina listino Price list page	 m	 Pz
F121010750	PP H 70	Nero Black	500	20	70	39	110	7200
F121010050	PP H 110	Nero Black	500	20	110	39	80	4800
F121011550	PP H 150	Nero Black	500	20	150	39	50	3000

PETTINE ANTINIDO IN LAMIERA PREVERNICIATA ANTI-NEST COMB IN PRE- PAINTED SHEET METAL



INOX

PRODOTTO / PRODUCT

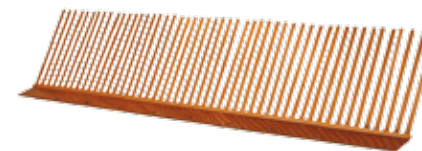
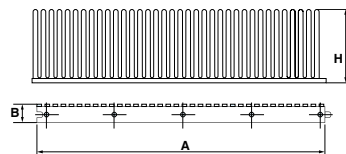

Codice Code	Tipo Type	Colore Colour	A	B	H	Pagina listino Price list page	 m	 Pz
F121030050	Preverniciato H 110 Prepainted	Testa di moro Dark brown	500	20	110	39	50	2000

PETTINE ANTINIDO IN RAME COPPER ANTI- NEST COMB



CU

PRODOTTO / PRODUCT

Codice Code	Tipo Type	Colore Colour	A	B	H	Pagina listino Price list page	 m	 Pz
F121020050	Rame H 110 Copper	Rame Copper	500	20	110	39	50	2000

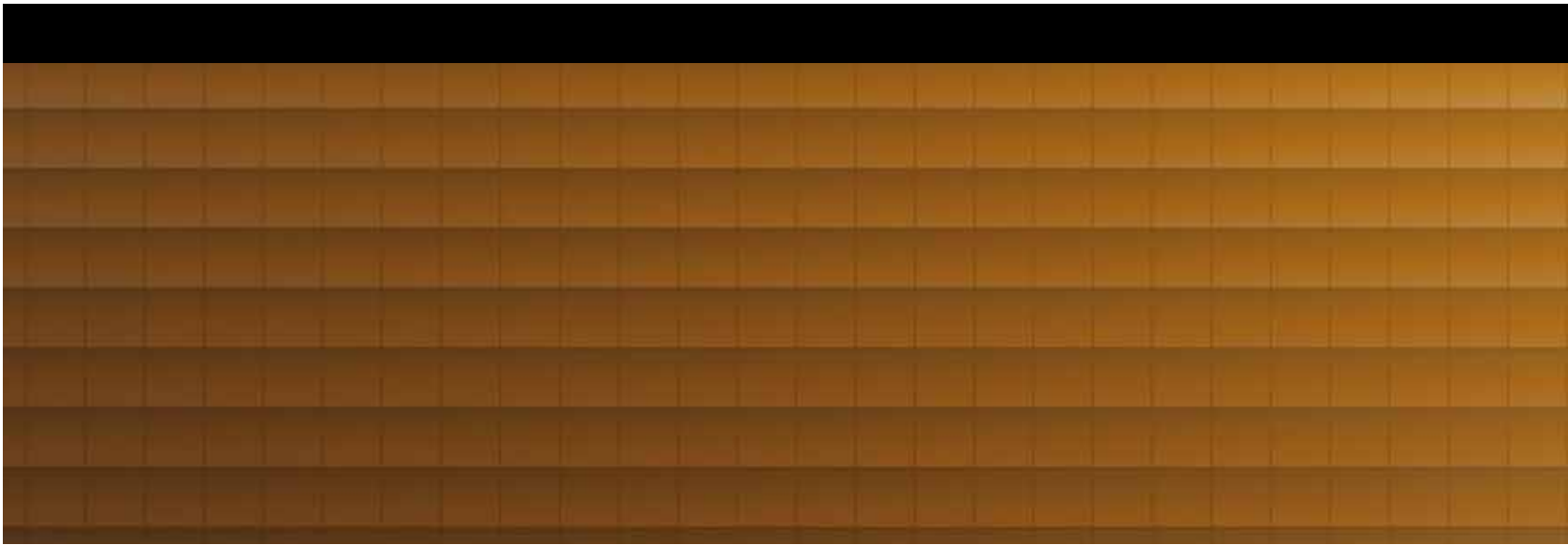

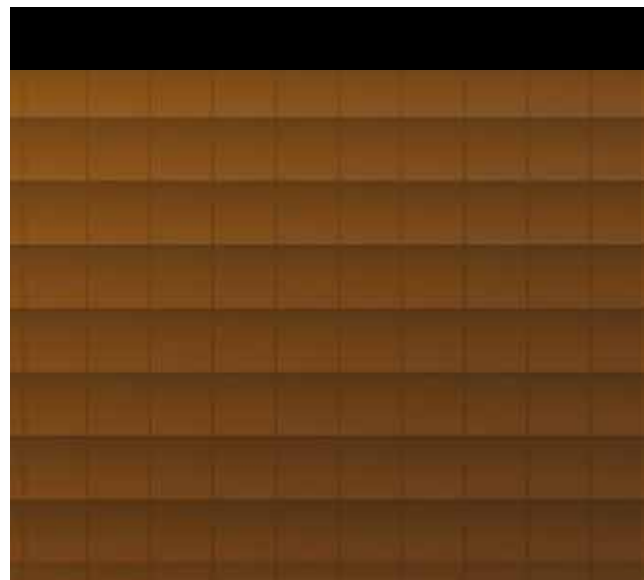
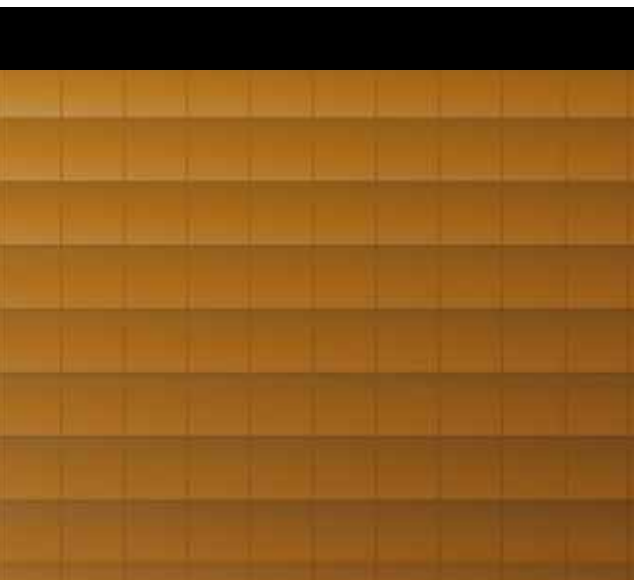



LEGENDA PRODOTTI PRODUCTS INDEX

-  Piezoelettrico
Piezo ignition
-  On/Off automatico
Trigger on/off
-  Innesto a baionetta
Bayonet fitting
-  Attacco girevole
Swivel hose nipple
-  Valvola regolazione fiamma principale
Precise main flame adjustment valve
-  Valvola regolazione fiamma pilota
Precise pilot flame adjustment valve
-  Pulsante cambio fiamma
Trigger for shifting between pilot and main flame
-  Valvola regolazione fiamma principale
Precise main flame adjustment valve
-  Peso ridotto
Light-weight

LEGENDA APPLICAZIONI APPLICATIONS INDEX

-  Precisione
Precision
-  Saldatura
Brazing
-  Riscaldamento
Heating
-  Termo-retrazione
Shrinking
-  Saldatura Impermeabilizzazione
Waterproofing / Welding

CODICE COLORE COLOR CODE

-  **B** Promatic
-  **R** Pro 88

NB.: LE MISURE INDICATE NEL PRESENTE CATALOGO SONO ESPRESSE IN MM, SALVO DIVERSE INDICAZIONI.
NB.: ALL MEASURES IN THIS CATALOGUE ARE EXPRESSED IN MM, IF NOT OTHERWISE INDICATED.



INTRODUZIONE MASTER / MASTER INTRODUCTION	p.118
PROMATIC - IL SISTEMA DI SALDATURA UNIVERSALE / PROMATIC - THE UNIVERSAL TORCH SYSTEM	p.120
Promatic Promatic	p.122
Sievert Promatic impugnatura 3366 Sievert Promatic handle 3366	p.123
Brucciatori ad aria calda Hot-air burners	p.124
Brucciatori ad alta resa per impermeabilizzazione ed altri lavori ad alto dispendio di calore Power burners for waterproofing and other heat demanding works	p.126
PRO 88 - SISTEMA DI SALDATURA PER APPLICAZIONI PESANTI / PRO 88 - HEAVY-DUTY TORCH SYSTEM	p.128
Pro 88 Pro 88	p.130
Sievert Pro 88 impugnatura 3488 Sievert Pro 88 handle 3488	p.131
Aste Sievert Pro 88 Sievert Pro 88 neck tubes	p.132
Brucciatori ad alta resa per impermeabilizzazione ed altri lavori ad alto dispendio di calore Power burners for waterproofing and other heat demanding works	p.132
Kit saldatura con bruciatori ad alta resa Power burner torch kits	p.133
Pro 88 - Gamma titanio Pro 88 - Titanium range	p.134
Kit completi ad alta resa in titanio Power burner torch kits, titanium	p.135
KIT SOS PROMATIC / PROMATIC KIT SOS	p.136
TUBI FLESSIBILI PER GAS PROPANO E ACCESSORI / PROPANE HOSES AND ACCESSORIES	p.140
Tubi e accessori Hoses & accessories	p.142
REGOLATORI DI PRESSIONE E VALVOLE DI SICUREZZA / REGULATORS AND HOSE FAILURE VALVES	p.144
DW 3000 - IL RIVOLUZIONARIO UTENSILE AD ARIA CALDA PROFESSIONALE / DW 3000 - THE REVOLUTIONARY HOT-AIR TOOL	p.146
DW 3000 DW 3000	p.148
Rullini e accessori per la saldatura Rollers & Welding accessories	p.150
TW 5000 - SALDATURE CONTINUE DI GRANDE QUALITÀ TW 5000 - HIGH QUALITY WELDING RESULT	p.154
TW 5000 TW 5000	p.156



STRUMENTI E ACCESSORI PER LA POSA

INSTALLATION TOOLS AND ACCESSORIES

Strumenti e accessori per la posa dei manti impermeabili, sia sintetici sia bituminosi. Cannelli, rulli, saldatrici ad aria calda, accessori per il taglio delle membrane e la pulizia delle superfici.

Con il vantaggio di un unico fornitore che si occupa dei prodotti tecnici e che seleziona gli strumenti, le apparecchiature e gli utensili di uso quotidiano in cantiere.

Tools and accessories for installing synthetic and bituminous waterproofing membranes. Torches, rollers, hot-air welders and accessories for cutting the membranes and cleaning the application surfaces.

With the advantage of having a single supplier for providing the technical products, as well as for selecting the tools, equipment and utensils required for daily on-site use.



TUTTO QUEL
CHE SERVE

EVERYTHING
YOU NEED



PROMATIC
IL SISTEMA DI
SALDATURA
UNIVERSALE

PROMATIC
THE UNIVERSAL
TORCH SYSTEM

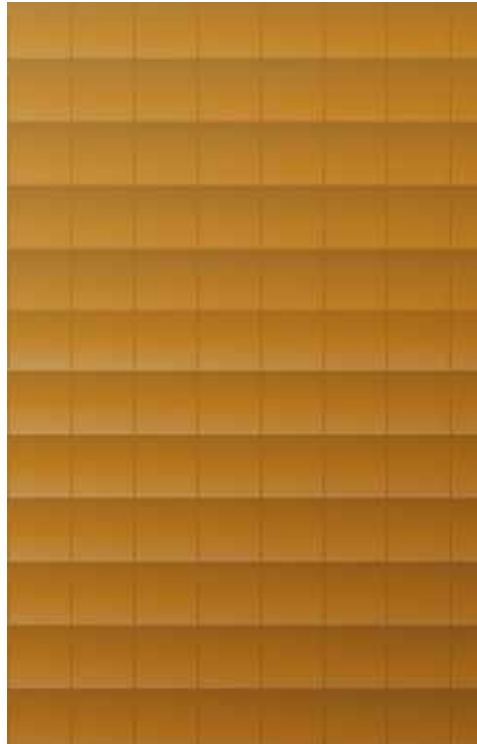

Promatic è il sistema più completo ed avanzato della gamma Sievert.
Grazie all'accensione piezoelettrica brevettata, l'ampia gamma di accessori, l'impugnatura universale, moderna ed ergonomica, Promatic è riconosciuto come la migliore soluzione per tutte le possibili applicazioni a caldo dove l'efficienza e la sicurezza dell'utilizzatore sono i requisiti più importanti.
Il sistema top di gamma Sievert Promatic lavora utilizzando gas propano e butano.

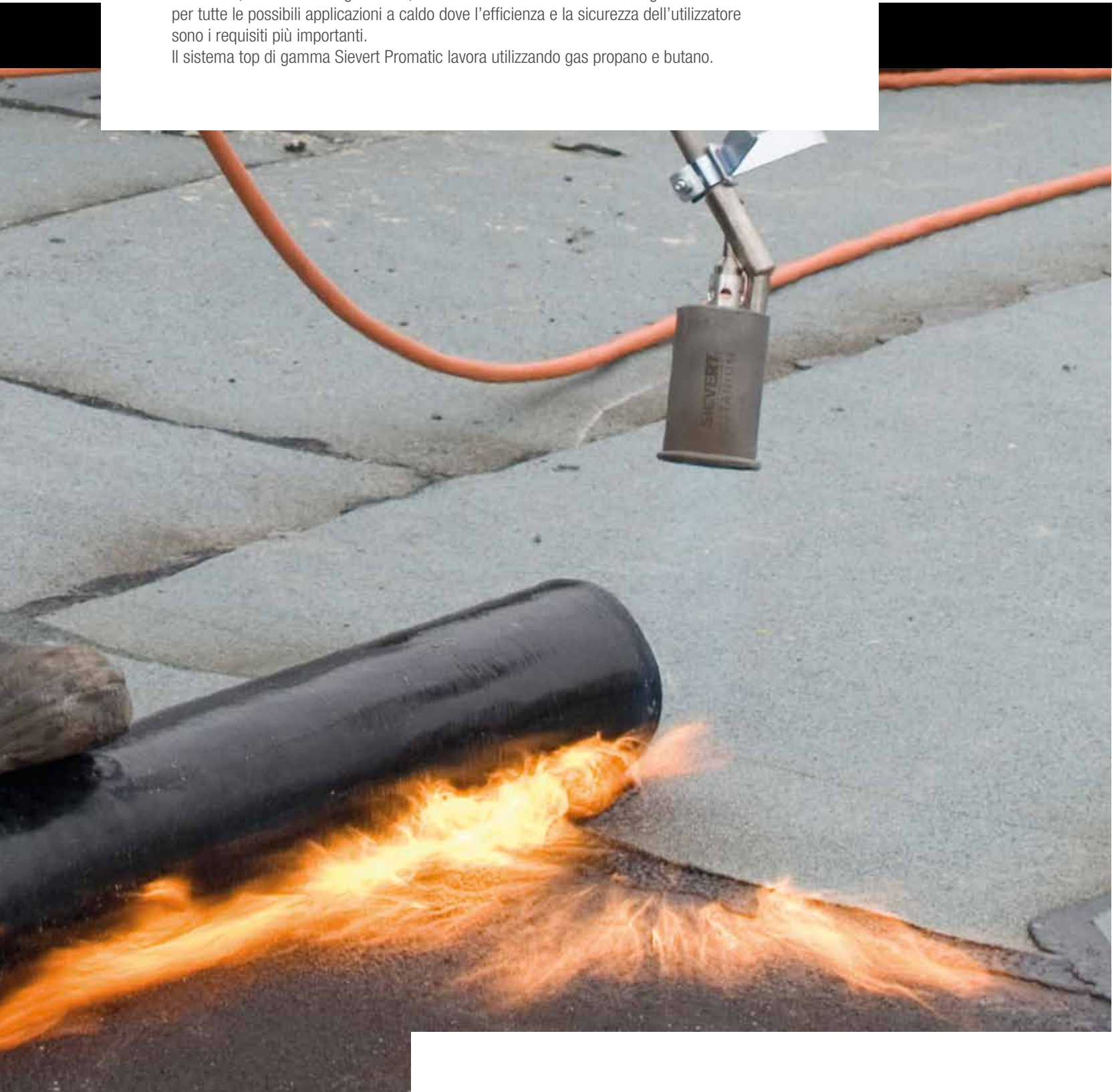

Promatic is the most complete and advanced system in our range.
The patented piezoelectric ignition, universal handle, range of accessories, advanced design and ergonomic appearance make Promatic a world-beating system for all possible heating tasks where efficiency and professional workmanship are the most important requirements.
Promatic - Sievert's top of the line torch system operates with propane and butane gases.

PROMATIC

PROMATIC

Impermeabilizzazione
Waterproofing/Welding



Bruciatori ad aria calda
Hot-air burners



M120335890
32x15 mm



Bruciatori ad alta resa
Power burners



M120335302
Ø 60 mm

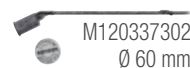

M120337302
Ø 60 mm



M120335002
Ø 40 mm



M120335602
Ø 60 mm



System



Impugnatura in materiale plastico composito rinforzato con il 30% di fibra di vetro per una massima resistenza.
Impugnatura ergonomica in materiale bicomponente per un massimo comfort e facilità di utilizzo.
Accensione piezoelettrica con grilletto con funzione on/off istantaneo.
Innesto a baionetta per i bruciatori.
Attacco girevole del tubo per evitare attorcigliamenti.
Gancio per appendere e base d'appoggio.
Valvola per regolazione di fiamma precisa.
Raccordo tubo non incluso.

Plastic composite handle reinforced with 30% glass fibres for maximum durability.
Double moulded soft grip for highest comfort and usability.
Piezo igniton with instant trigger on/off function.
Bayonet fitting for burners.
Swivelling hose connection to avoid hose drag.
Combined suspension hook and footstand.
Valve for precise flame setting.
Delivered without hose nipple.



SIEVERT PROMATIC IMPUGNATURA 3366

SIEVERT PROMATIC HANDLE 3366



Grilletto anti affaticamento con accensione piezo automatica.
Funzione on/off del pulsante.

Load relieving trigger system with automatic Piezo ignition.
Trigger on/off function.



Raccordo tubo girevole.
Valvola per la regolazione precisa della fiamma.

Swivel hose nipple.
Precise flame adjustment valve.



Blocco fuoriuscita gas se il bruciatore a baionetta non è inserito.
Impugnatura ergonomica confortevole.

No gas emission unless burner fitted.
Bayonet fitted burners.
Ergonomic softgrip handle.



PRODOTTO / PRODUCT

Codice Code	Attacco tubo Hose connections	Pressione di esercizio, bar Working pressure, bar	Lunghezza, mm Length, mm	Altezza, mm Height, mm	Peso, g Weight, g	Pagina listino Price list page
M120336611	BSP 3/8"LH	1,5 - 4	180	80	290	42

BRUCIATORI AD ARIA CALDA

HOT-AIR BURNERS

BRUCIATORI SPECIALI
PER PVC E TPO
SPECIAL BURNERS FOR
PVC AND TPO

System



Bruciatore ad aria calda antivento con potente flusso d'aria per scaldare PVC o altre membrane laddove l'utilizzo della fiamma libera non è possibile o raccomandabile. Pressione di esercizio 2 bar.

Hot-air burners with powerful windproof hot-air streams for heating PVC or other rubber membranes where an open flame not is suitable. Working pressure 2 bar.

PRODOTTO / PRODUCT

Codice Code	Diametro bruciatore, mm Burner diameter, mm	Consumo gas, g/h 2 bar Gas consumption, g/h 2 bar	Effetto calorico, kW Effect, kW	Pagina listino Price list page
M120335890	32x15	55	0,7	42



BRUCIATORI AD
ALTA RESA PER
IMPERMEABILIZZAZIONE
ED ALTRI LAVORI AD ALTO
DISPENDIO DI CALORE

POWER BURNERS
FOR WATERPROOFING
AND OTHER HEAT
DEMANDING WORKS

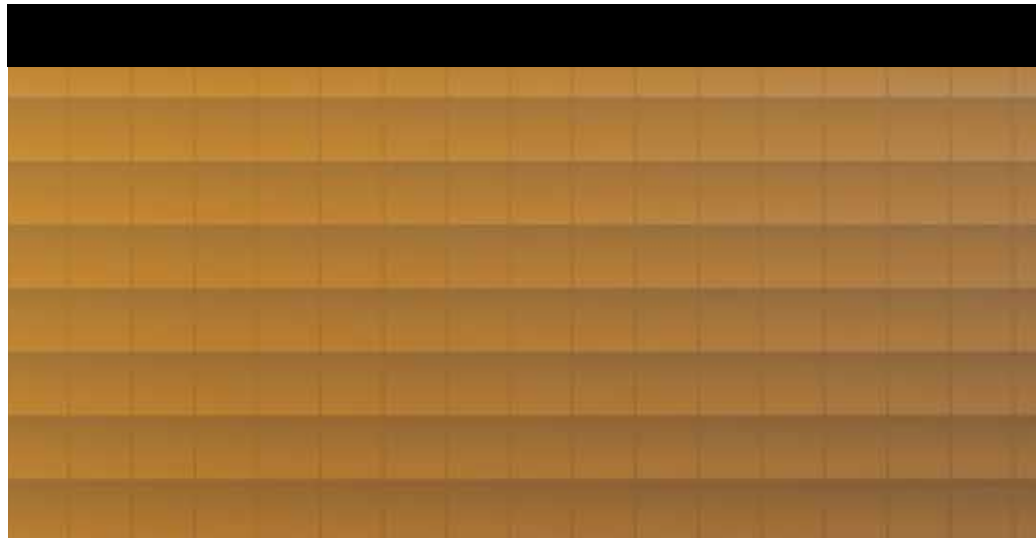

System



BRUCIATORI AD
ALTA RESA
POWER
BURNERS



Bruciatori ad alta capacità con fiamme estremamente forti e antivento, ideali per lavori di copertura e riscaldamento su ampie superfici. Asta lunga per un comodo utilizzo a terra. Pressione di esercizio raccomandata 4 bar.

High capacity power burners with extremely strong and windproof flames for roofing works and for large-scale heating applications. Long burners for field torching. Recommended working pressure 4 bar.

PRODOTTO / PRODUCT

Codice Code	Diametro bruciatore, mm Burner diameter, mm	Consumo gas, g/h 4 bar Gas consumption, g/h 4 bar	Effetto calorico, kW Effect, kW	Lunghezza bruciatore, mm Burner length, mm	Pagina listino Price list page
M120335402	60	8000	102	500	42
M120335302	60	8000	102	600	42

**BRUCIATORE AD ALTA RESA
IN TITANIO**
POWER BURNERS,
TITANIUM



Bruciatore con peso complessivo ridotto del 60% rispetto ad un tradizionale bruciatore ad alta resa. Riduce l'affaticamento con un uso prolungato.

High capacity power burners with weight reduced by 60% compared to traditional roofing burners on the market. Saves your body.

PRODOTTO / PRODUCT					
Codice Code	Diametro bruciatore, mm Burner diameter, mm	Consumo gas, g/h 4 bar Gas consumption, g/h 4 bar	Effetto calorico, kW Effect, kW	Lunghezza bruciatore, mm Burner lenght, mm	Pagina listino Price list page
M120337302	60	8000	102	600	42

**BRUCIATORI AD ALTA RESA PER DETTAGLI
E RIPARAZIONI**
DETAIL POWER BURNERS



Bruciatori corti per eseguire lavori di dettaglio su tetti e altre applicazioni di riscaldamento quali preriscaldamento e restringimento termico su grandi condutture. Riduce l'affaticamento con un uso prolungato. Pressione di esercizio raccomandata 4 bar.

Short burners for detail work on roofs and other heating applications such as preheating before welding and shrinking on pipelines. Recommended working pressure 4 bar.

PRODOTTO / PRODUCT					
Codice Code	Diametro bruciatore, mm Burner diameter, mm	Consumo gas, g/h 4 bar Gas consumption, g/h 4 bar	Effetto calorico, kW Effect, kW	Lunghezza bruciatore, mm Burner lenght, mm	Pagina listino Price list page
M120335002	40	3350	43,5	250	43
M120335602	60	8000	102	250	43

PRO 88
SISTEMA DI SALDATURA
PER APPLICAZIONI
PESANTI

PRO 88
HEAVY-DUTY TORCH
SYSTEM

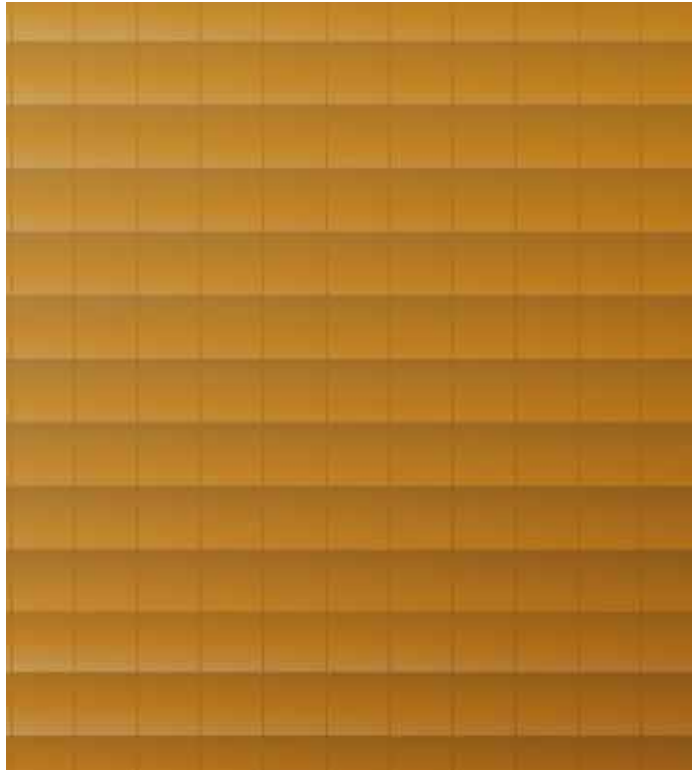

Il sistema Pro 88 è usato in tutto il mondo dai migliori carpentieri e impermeabilizzatori. Grazie al programma completo di bruciatori, inclusa la serie Titanium, Pro 88 è il sistema di saldatura ideale per le applicazioni più estreme. Il sistema Pro 88 lavora con gas propano e butano.

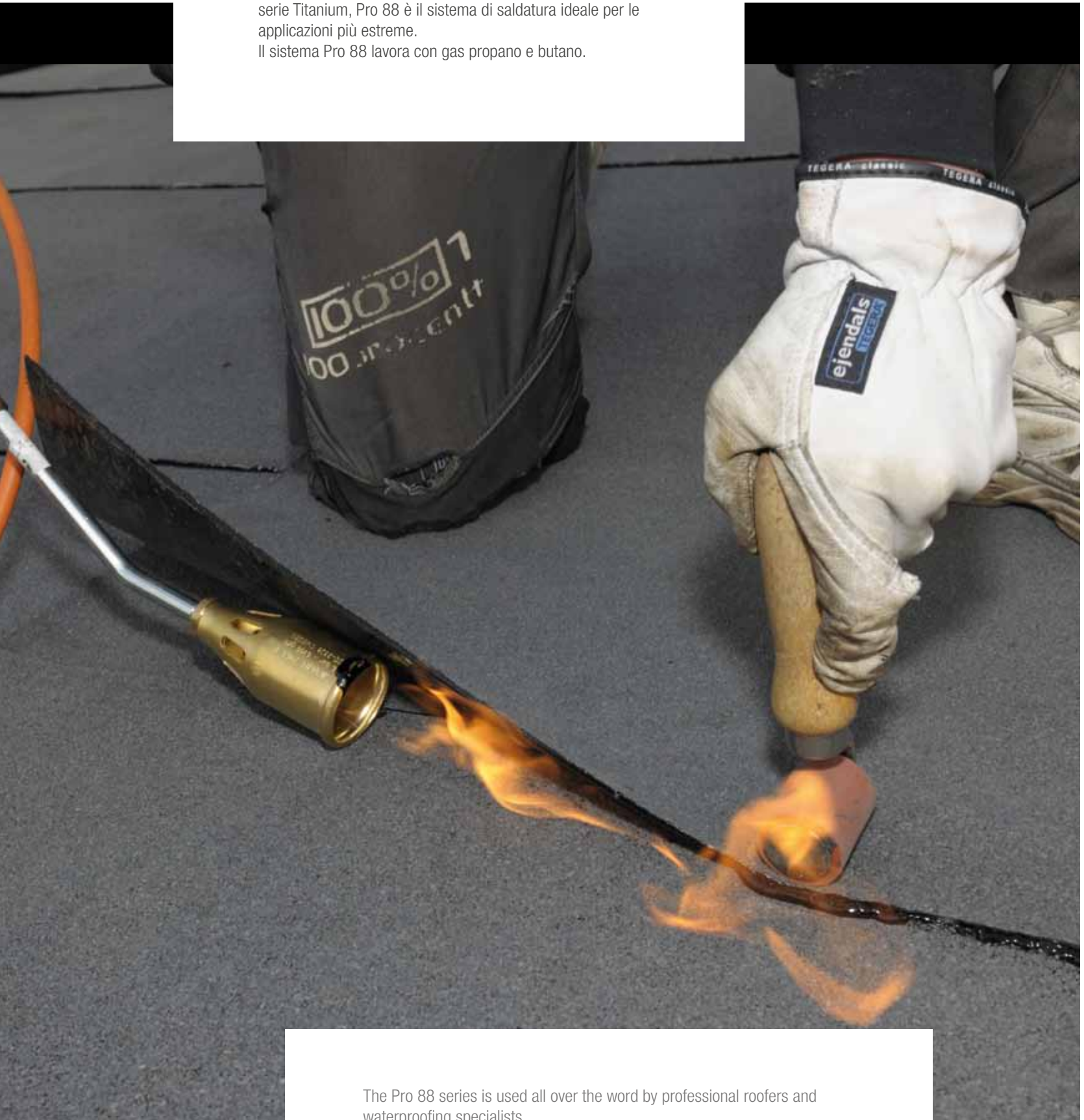

The Pro 88 series is used all over the world by professional roofers and waterproofing specialists. With a complete power burner programme, including Titanium torches, the Pro 88 is the ultimate torch system for heavy-duty works. The Pro 88 series operates with propane and butane gases.

PRO 88

PRO 88



Impermeabilizzazione Saldatura
Waterproofing/Welding



Bruciatori ad alta resa
Power burners

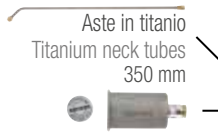

Aste in titanio
Titanium neck tubes
350 mm

Bruciatori in titanio
Titanium burners
Ø 50-70 mm



Kit bruciatori titanio
Titanium burners kit
Ø 60-70 mm / 500 mm



Aste in ottone
Brass neck tubes
100-750 mm

Bruciatori in ottone
Brass burners
Ø 35-50 mm



Kit completi
con bruciatore
Titanium burners kit



System



Impugnatura a doppia regolazione ideale per i bruciatori più grandi. Racchiude un regolatore principale e un regolatore di risparmio che agisce sull'erogazione della fiamma pilota. Leva di apertura per passare istantaneamente da fiamma principale a fiamma pilota o per utilizzare la fiamma principale a intermittenza. Parti metalliche realizzate in ottone di alta qualità. Impugnatura ergonomica realizzata in materiale bi componente. Raccordo tubo non incluso.

Double valved handle mainly for larger burners. Incorporates one main valve and one economizer valve enabling a gas saving pilot flame. Trigger for instant shifting between pilot and main flame and for pulsing the main flame. All metal parts made of high quality brass. Ergonomically designed plastic composite handle. Delivered without hose nipple.



SIEVERT PRO 88 IMPUGNATURA 3488

SIEVERT PRO 88 HANDLE 3488



Leva di apertura per passare istantaneamente da fiamma principale a fiamma pilota o per utilizzare la fiamma principale a intermittenza.

Trigger for shifting between pilot and main flame and for pulsing the main flame.



Precisa regolazione della fiamma principale e della fiamma pilota. Fiamma pilota per risparmiare gas. Impugnatura con doppio regolatore ideale per i bruciatori più grandi.

Precise flame adjustment of pilot and main flame. Pilot flame for gas saving. Double valved handle mainly for larger burners.



Ampia gamma di bruciatori ad alta resa per applicazioni estreme. Funzionamento con qualsiasi condizione atmosferica.

Wide range of burners for power applications. Works in all weather conditions.

LA GAMMA SIEVERT
INCLUDE ANCHE
BRUCIATORI E
PROLUNGHE IN TITANIO

SIEVERT HAS A
WIDE RANGE OF
TITANIUM BURNERS
AND NECKTUBES

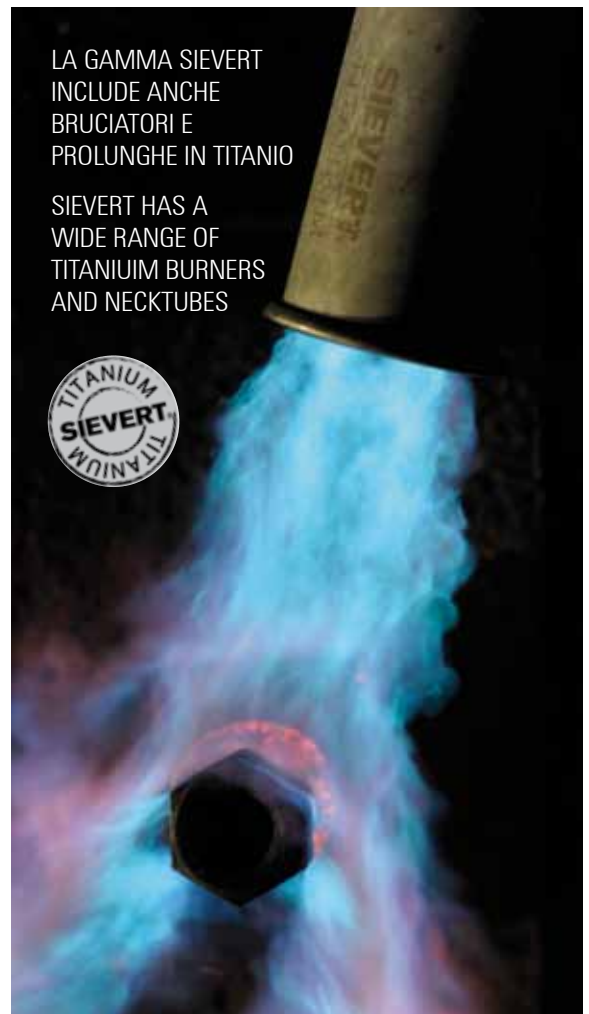

PRODOTTO / PRODUCT

Codice Code	Attacco tubo Hose connections	Pressione di esercizio, bar Working pressure, bar	Lunghezza, mm Length, mm	Altezza, mm Height, mm	Peso, g Weight, g	Pagina listino Price list page
M120348841	BSP 3/8"LH	1,5 - 8	205	90	385	43

ASTE SIEVERT PRO 88

SIEVERT PRO 88 NECK TUBES



Ampia gamma di prolunghe realizzate in ottone di elevata qualità.
Wide range of neck tubes made of high quality brass.



PRODOTTO / PRODUCT

Codice Code	Lunghezza Asta, mm Length Neck Tube, mm	Pagina listino Price list page
M120350601	750	43
M120350801	600	43
M120350701	500	43
M120351001	350	43
M120350902 con gancio M120350902 with hook	180	43

BRUCIATORI AD ALTA RESA PER IMPERMEABILIZZAZIONE ED ALTRI LAVORI AD ALTO DISPENDIO DI CALORE

POWER BURNERS FOR WATERPROOFING AND OTHER HEAT DEMANDING WORKS



Bruciatori leggeri ad alta capacità con fiamme estremamente forti e antivento per un utilizzo con qualsiasi condizione atmosferica. Ideali per lavori di asciugatura, posa bitume, preriscaldamento delle superfici da saldare, sciogliere ghiaccio e neve e riscaldamento di ampie superfici. Con raccordo adatto al collegamento diretto con le impugnature Sievert Pro. Pressione di esercizio raccomandata 4 bar.

Heavy-duty light weight power burners with extremely strong and windproof flames to withstand the severest weather conditions. Ideal for drying, bitumen laying, detail and field torching, preheating before welding, melting snow/ice and other heat demanding applications. For connection to Sievert Pro necktubes. Recommended working pressure 4 bar.

PRODOTTO / PRODUCT

Codice Code	Diametro bruciatore, mm Burner diameter, mm	Consumo gas, g/h 4 bar Gas consumption, g/h 4 bar	Effetto calorico, kW Effect, kW	Tipologia bruciatore Type power burners	Pagina listino Price list page
M120294302	35	3350	43,5	Ottone Brass	44
M120294402	50	6700	86	Ottone Brass	44
M120296001	60	8250	114	Acciaio Inox Stainless steel	44

KIT SALDATURA CON BRUCIATORI AD ALTA RESA

POWER BURNER TORCH KITS



System



Kit completi disponibili.

Complete kits available.



PRODOTTO / PRODUCT

Codice Code	Attacco tubo Hose connections	Diametro bruciatore, mm Burner diameter, mm	Consumo gas, g/h 4 bar Gas consumption, g/h 4 bar	Effetto calorico, kW Effect, kW	Lunghezza asta, mm Neck tube length, mm	Tipologia bruciatore Type power burners	Pagina listino Price list page
M120344441	BSP 3/8"LH	50	6700	86	180	Ottone Brass	44
M120500002	BSP 3/8"LH	50	6700	86	350	Acciaio al carbonio Carbon steel	44
M120346041	BSP 3/8"LH	60	8250	114	500	Acciaio Inox Stainless steel	44

PRO 88 GAMMA TITANIO

PRO 88 TITANIUM RANGE



System



LA SALUTE PRIMA DI TUTTO

Lavorare a lungo in condizioni difficili richiede utensili facili da utilizzare e in grado di ridurre l'affaticamento. I cannelli Sievert Titanium sono i più ergonomici bruciatori per coperture mai realizzati. Con una riduzione di peso del 60% rispetto ai bruciatori tradizionali, i Sievert Titanium riducono enormemente le sollecitazioni sul corpo durante l'utilizzo prolungato per ore e ore, ripetuto ogni giorno.

SAVE YOUR BODY

Working long days in tough conditions requires tools that are easy to handle and that prevent state of exhaustion. Sievert Titanium torches are the most ergonomic roofing burners ever created. With weight reduced by 60% compared to traditional burners, they will dramatically reduce the load on your body when working continuously for hours, days and months.

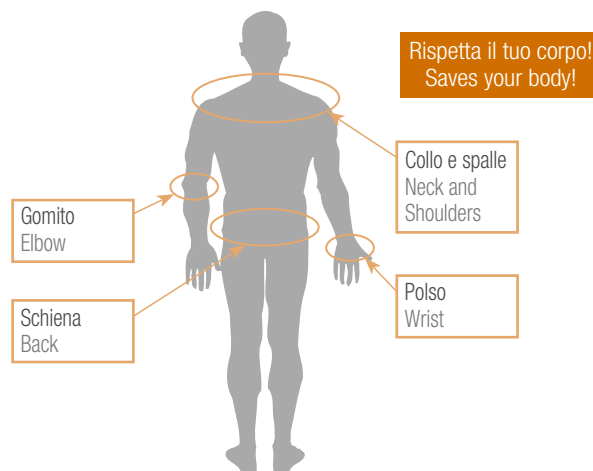

BRUCIATORI AD ALTA RESA POWER BURNERS

Bruciatori ad alta capacità con fiamme estremamente forti e antivento, per un impiego anche in condizioni estreme. Ideali per lavori di asciugatura, posa bitume, preriscaldamento delle superfici da saldare, sciogliere ghiaccio e neve e riscaldamento di ampie superfici. Con raccordo adatto al collegamento diretto con le impugnature Sievert Pro. Pressione di esercizio raccomandata 4 bar.

Heavy-duty light weight power burners with extremely strong and windproof flames to withstand the severest weather conditions. Ideal for drying, bitumen laying, detail and field torching, preheating before welding, melting snow/ice and other heat demanding applications. For connection to Sievert Pro necktubes. Recommended working pressure 4 bar.

Realizzati in titanio di elevatissima qualità
Made of high quality titanium



NEW



PRODOTTO / PRODUCT				
Codice Code	M120295001	M120295301	M120295401	M120295402
Diametro bruciatore, mm Burner diameter, mm	50	60	70	70
Consumo gas, g/h 4 bar Gas consumption, g/h 4 bar	6700	8250	12500	12500
Effetto calorico, kW Effect, kW	86	114	155	155
Pagina listino Price list page	44	44	44	44

ASTE IN TITANIO NECK TUBES, TITANIUM

Gamma di aste realizzate in titanio di elevatissima qualità da connettere ai bruciatori ad alta resa in titanio.

Range of neck tubes made of high quality titanium to connect power burners.



PRODOTTO / PRODUCT		
Codice Code	Lunghezza Asta, mm Lenght Neck Tube, mm	Pagina listino Price list page
M120355001	350	45
M120355701	500	45

KIT COMPLETI AD ALTA RESA IN TITANIO

POWER BURNER TORCH KITS, TITANIUM

Kit completi in titanio composti da impugnatura, asta e bruciatore in titanio, completo di base d'appoggio.

Complete torch kits with fixed power burners and footstand.



PRODOTTO / PRODUCT					
Codice Code	Diametro bruciatore, mm Burner diameter, mm	Consumo gas, g/h 4 bar Gas consumption, g/h 4 bar	Effetto calorico, kW Effect, kW	Lunghezza asta, mm Neck tube lenght, mm	Pagina listino Price list page
M120346051	60	8250	114	500	45
M120347052	70	12500	155	500	45



KIT SOS PROMATIC

PROMATIC KIT SOS

Sistema di saldatura portatile, pratico e leggero per lavori di riparazione di membrane plastiche e bituminose.

Portable welding kit, easy to use and lightweight, designed for plastic and bituminous membranes repairing.



PROPANO
PREMIUM
QUALITY-1925°
PROPANO
PREMIUM
QUALITY-1925°



System



Bombola di gas Propano/Butano da 750 ml
750 ml Propane/Butane disposable cartridge

PRODOTTO / PRODUCT								
Codice Code	Attacco Connection	Peso (g) Weight (g)	Contenuto (g) Contents (g)	Contenuto (ml) Contents (ml)	Miscela Gas Gas mixture	ADR (trasorto) ADR	Standard Standard	Pagina listino Price list page
M120220885	EU 7/16"	536	405	750	Propano/Butano Propane/Butane	UN 2037	EN 417	45

GANCIO PER APPENDERE
SUSPENSION AND
CARRYING HOOK



Gancio in acciaio inox
Stainless steel hook

PRODOTTO / PRODUCT		
Codice Code	Descrizione Description	Pagina listino Price list page
M120884104	Gancio in acciaio inox Belt hook	46



**RIDUTTORE CON PRESSIONE
REGOLABILE PER CARTUCCE
REGULATORS WITH ADJUSTABLE
PRESSURE FOR CARTRIDGES**



Regolatore di pressione variabile 0-2 bar, con attacco BSP 3/8" adattabile alle bombole Art. M120220885

Regulator with adjustable pressure 0-2 bar for cartridges M120220885, hose connection BSP 3/8"

PRODOTTO / PRODUCT

Codice Code	Connessione Connection Type	Attacco Tubo Hose connexion Type	Pressione Pressure	Capacità max Max capacity	Pagina listino Price list page
M120265012	EU 7/16" cartridge	BSP 3/8"LH	0 - 2 bar	-	46

KIT SOS PROMATIC

PROMATIC KIT SOS



TUBO GAS PROPANO PROPANE HOSE



Diametro 5 mm EN 559 / ISO 3821
Diameter 5 mm EN 559 / ISO 3821

PRODOTTO / PRODUCT

Codice Code	Tipologia attacco Connection Type	Raccordi Connections	Lunghezza, m Length, m	Pagina listino Price list page
M120717321	Fisso Fixed	BSP 3/8"LH/ BSP 3/8"LH	2	46

PROMATIC IMPUGNATURA PROMATIC HANDLE



Impugnatura piezoelettrica PROMATIC - BSP 3/8"LH
PROMATIC handle with piezo - BSP 3/8"LH

PRODOTTO / PRODUCT

Codice Code	Attacco tubo Hose connections	Pressione di esercizio, bar Working pressure, bar	Lunghezza, mm Length, mm	Altezza, mm Height, mm	Peso, g Weight, g	Pagina listino Price list page
M120336611	BSP 3/8"LH	1,5 - 4	180	80	290	46

BRUCIATORE SPECIALE SPECIAL BURNER



Bruciatore ad aria calda per saldatura di membrane in PVC/TPO
dimensione del beccuccio 32 x 15 mm
Hot air burner for PVC and TPO 32 x 15 mm

PRODOTTO / PRODUCT

Codice Code	Diametro bruciatore, mm Burner diameter, mm	Consumo gas, g/h 2 bar Gas consumption, g/h 2 bar	Effetto calorico, kW Effect, kW	Pagina listino Price list page
M120335890	32 x 15	55	0,7	47

**BRUCIATORI AD ALTA RESA
POWER BURNERS**



Bruciatore di potenza 250 mm, diametro campana 40 mm
Power burner 250 mm lenght 40mm diameter



Bruciatore di potenza 250 mm, diametro campana 60 mm
Power burner 250 mm lenght 60mm diameter

PRODOTTO / PRODUCT					
Codice Code	Diametro bruciatore, mm Burner diameter, mm	Consumo gas, g/h 2 bar Gas consumption, g/h 2 bar	Effetto calorico, kW Effect, kW	Lunghezza bruciatore, mm Burner lenght, mm	Pagina listino Price list page
M120335002	40	3350	43,5	250	47
M120335602	60	8000	102	250	47

**BORSA PORTA ATTREZZI
TOOL BAG**



Borsa Sievert small
Bag Sievert small

PRODOTTO / PRODUCT		
Codice Code	Descrizione Description	Pagina listino Price list page
M120500012	Borsa porta attrezzi Canvas bag with zipper	47



TUBI FLESSIBILI
PER GAS PROPANO
E ACCESSORI

PROPANE HOSES
AND ACCESSORIES

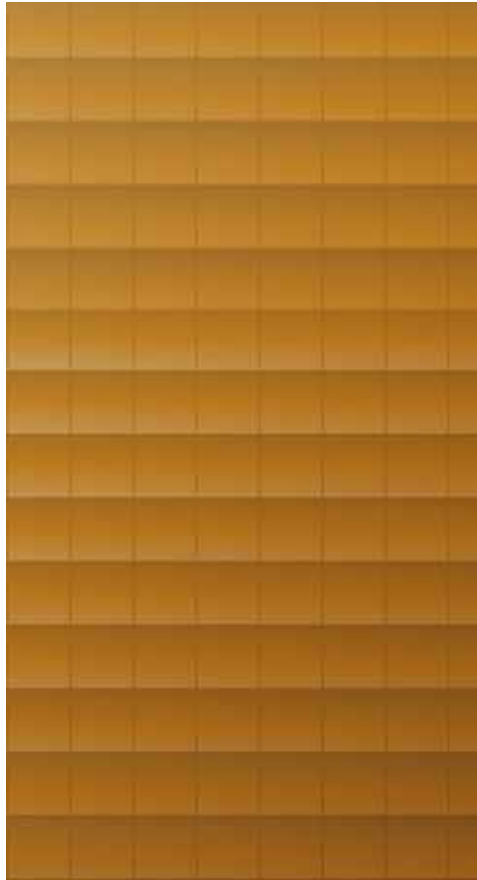

La gamma Sievert di tubi flessibili ad alta pressione sono conformi agli standard EN 559/ISO 3821. Grazie all'elevata resistenza al freddo, possono essere utilizzati con temperature fino a -30°C . I tubi Sievert presentano all'interno un sottostrato nero liscio in gomma, ricoperto da una rete di fili sintetici ad alta tenacità, seguita all'esterno da una copertura color arancione in grado di resistere sia alle intemperie che a danni accidentali.

I tubi flessibili Sievert sono disponibili con diametro interno da 5 mm e 8 mm. La lunghezza varia da bobine di 50 metri a formati più corti già raccordati e testati per verificarne l'assenza di perdite.

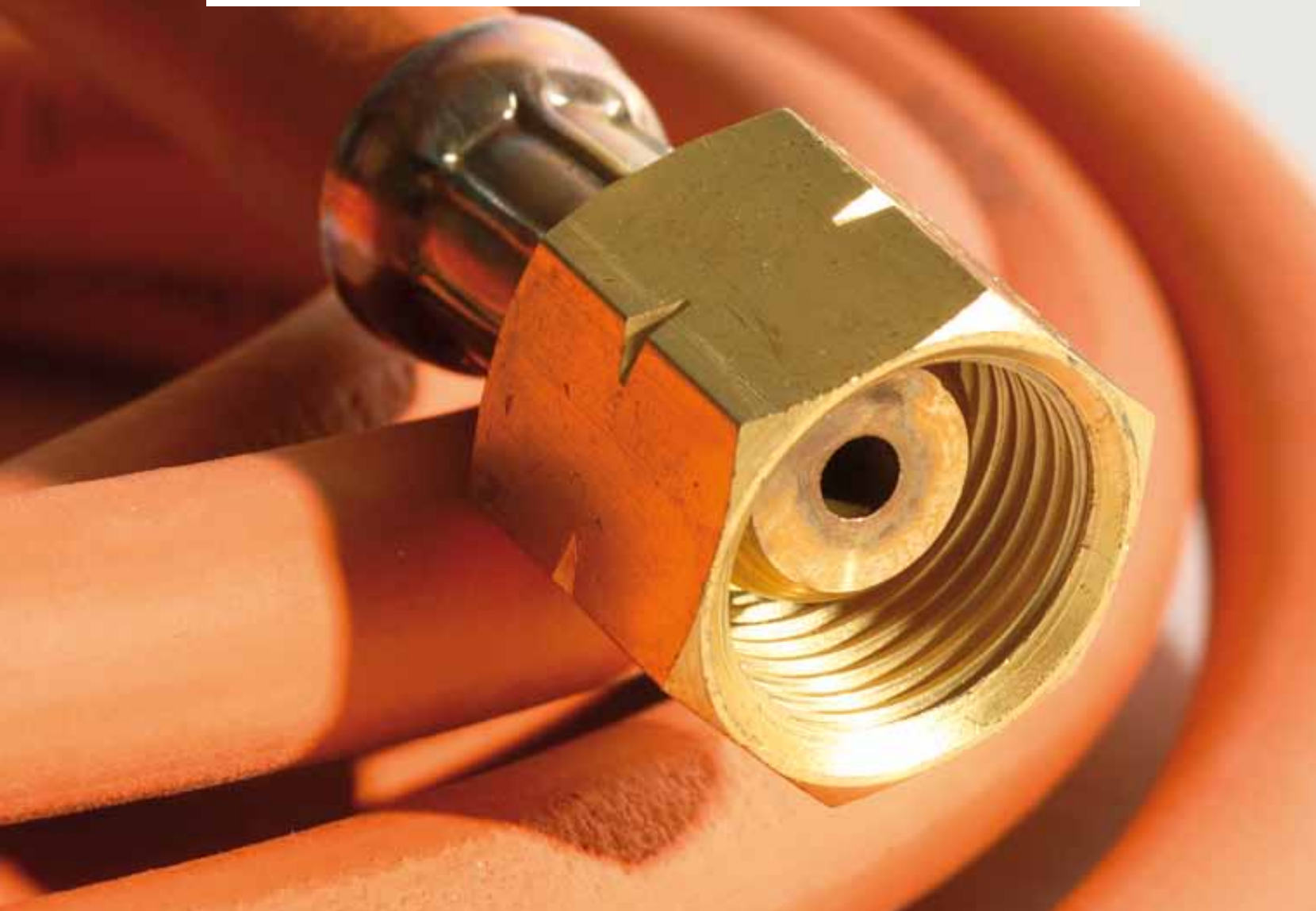

Sievert high pressure hoses conform to the EN 559/ISO 3821 standards. Sievert hoses are also extra frost resistant and can be used in temperatures down to -30°C . The Sievert hose is designed with an inner layer of black gas resistant rubber, a middle layer of reinforcing weave to withstand high pressure and an outer orange coloured layer to protect against external damage, sunlight and ozone.

Sievert hoses are available with inside diameters of 5 mm and 8 mm in 50 meter rolls or as factory fitted and leak tested hose kits.

TUBI E ACCESSORI

HOSES & ACCESSORIES



TUBI GAS PROPANO 5 MM PROPANE HOSES 5 MM



Diametro 5mm EN 559 / ISO 3821
Diameter 5mm EN 559 / ISO 3821



Compatibile con KIT SOS
Compatible with SOS KIT

PRODOTTO / PRODUCT

Codice Code	Tipologia attacco Connection Type	Raccordi Connections	Lunghezza, m Length, m	Pagina listino Price list page
M120717320	Fisso/Girevole Fixed/Swivel	BSP 3/8"LH/ BSP 3/8"LH	2	48

TUBI GAS PROPANO 8 MM PER BRUCIATORI DI GRANDI DIMENSIONI PROPANE HOSES 8 MM FOR LARGE BURNERS



Flessibile
Diametro 8 mm EN 559 / ISO 3821
Flexible
Diameter 8 mm EN 559 / ISO 3821



Compatibile con PROMATIC
Compatible with PROMATIC



Compatibile con PRO 88
Compatible with PRO 88

PRODOTTO / PRODUCT

Codice Code	Tipologia attacco Connection Type	Raccordi Connections	Lunghezza, m Length, m	Pagina listino Price list page
M120836990	-	-	Rotolo 50 metri 50 meters roll	48
M120701510	Fisso/Girevole Fixed/Swivel	BSP 3/8"LH/ BSP 3/8"LH	Rotolo 10 metri 10 meters roll	48

RACCORDI
PORTAGOMMA FISSI
HOSE NIPPLES
FIXED



Compatibile con PROMATIC
Compatible with PROMATIC

PRODOTTO / PRODUCT			
Codice Code	Filettatura Thread	Diametro interno tubo, mm Inside hose, mm	Pagina listino Price list page
M120709180	BSP 3/8"LH	5 e/and 8	48

RACCORDI
PORTAGOMMA GIREVOLI
HOSE NIPPLES
SWIVEL



Compatibile con PRO88
Compatible with PRO88

PRODOTTO / PRODUCT			
Codice Code	Filettatura Thread	Diametro interno tubo, mm Inside hose, mm	Pagina listino Price list page
M120717331	BSP 3/8"LH	5 e/and 8	49

REGOLATORI DI PRESSIONE E VALVOLE DI SICUREZZA

REGULATORS AND HOSE FAILURE VALVES



I regolatori di pressione Sievert sono realizzati in ottone per garantire massima qualità e grande longevità. Le valvole sono caratterizzate da un'elevatissima capacità e una pressione di uscita molto precisa.

Sievert regulators are manufactured in brass to ensure the highest quality and long service life. The valves have a very high capacity and precise outlet pressure.

PERCHÈ UTILIZZARE UN REGOLATORE DI PRESSIONE?

La maggior parte dei bruciatori per Promatic necessitano di una pressione costante a 2 bar per funzionare in maniera ottimale, così come alcuni bruciatori per Pro 86/88, ad esempio quelli a fiamma ciclonica. Altri bruciatori possono lavorare con una pressione superiore ma è sempre vantaggioso ridurre la pressione proveniente dalle bombole di gas propano. Il vantaggio principale è quello di poter stabilizzare la pressione in modo da mantenerla costante sia nelle gelide giornate invernali così come in quelle torride estive.

WHY USE A REGULATOR?

Certain Pro 86/88 burners, such as cyclone burners and most Promatic burners, require a steady pressure of 2 bar in order to perform well. Other burners can also operate under higher pressures but it is still an advantage to reduce the pressure from the propane cylinder. The advantage is that the pressure can be stabilized to obtain the same pressure on a warm summer's day as on a cold winter's day.

PERCHÈ USARE UNA VALVOLA DI SICUREZZA (HFV)?

Una valvola di sicurezza (Hose Failure Valve) aumenta la sicurezza perché interrompe l'erogazione del gas in caso di rottura del tubo flessibile o di altre fughe di gas. L'utilizzo di valvole di sicurezza è consigliato soprattutto sui tubi flessibili più lunghi. Il raccordo al tubo ruota liberamente sul corpo valvola, riducendo il rischio che il tubo si possa aggrovigliare.

WHY USE A HOSE FAILURE VALVE?

A hose failure valve improves safety by cutting off the gas flow in case of a hose rupture or some other major gas leak. The use of hose failure valves is especially recommended on long hoses. The hose connection rotate freely on the valve housing, which reduces the risk of the hose becoming entangled.



RIDUTTORE CON PRESSIONE
REGOLABILE PER CARTUCCE
REGULATORS WITH
ADJUSTABLE PRESSURE
FOR CARTRIDGES



PRODOTTO / PRODUCT					
Codice Code	Connessione Connection Type	Attacco Tubo Hose connexion Type	Pressione Pressure	Capacità max Max capacity	Pagina listino Price list page
M120265012	EU 7/16" cartridge	BSP 3/8"LH	0 - 2 bar	-	49

RIDUTTORE CON
PRESSIONE REGOLABILE
REGULATOR WITH
ADJUSTABLE PRESSURE



PRODOTTO / PRODUCT					
Codice Code	Connessione Connection Type	Attacco Tubo Hose connexion Type	Pressione Pressure	Capacità max Max capacity	Pagina listino Price list page
M120306314	Italia	BSP 3/8"LH	1 - 4 bar	5 - 12 kg/h	49

MANOMETRO
MANOMETER



PRODOTTO / PRODUCT		
Codice Code	Compatibilità Compatibility	Pagina listino Price list page
M120720730	Compatibile con cod. 306314 Compatible with code 306314	49

Regolatori per altri paesi disponibili su commessa / Regulators with other country standard connections available on request

DW 3000
IL NUOVO RIVOLUZIONARIO
UTENSILE AD ARIA CALDA
PROFESSIONALE

DW 3000
THE REVOLUTIONARY
HOT-AIR TOOL

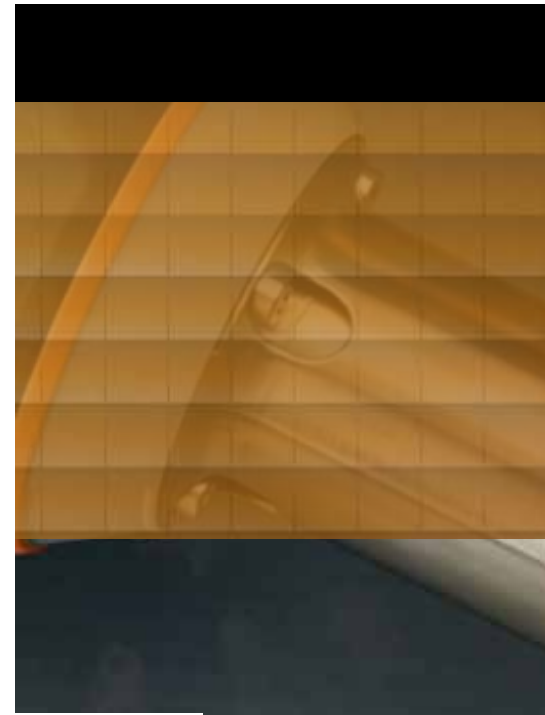
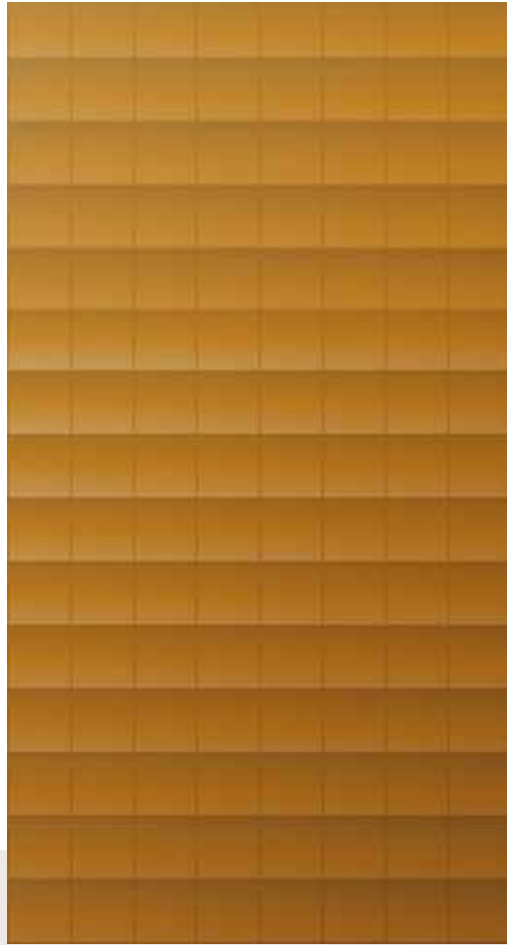

DW 3000 è il prodotto Sievert più avanzato e user-friendly di sempre. Con il suo design moderno e innovativo DW 3000 è destinato a rompere gli schemi e diventa il nuovo punto di riferimento nella saldatura ad aria calda grazie a prestazioni eccellenti, design ergonomico e peso estremamente ridotto.

DW 3000 è potente, preciso e affidabile grazie al motore senza spazzole e ad un'elettronica di nuova generazione. Il cuore elettronico di DW 3000 è rivoluzionario e permette di controllare con estrema precisione la temperatura e la potenza dell'apparecchio, per prestazioni mai viste prima. Siamo orgogliosi di presentarvi il nuovo e rivoluzionario utensile ad aria calda Sievert.



The most advanced yet user-friendly product ever made by Sievert. The revolutionary DW 3000 represents the modern day hot-air tool. The innovative and modern design of the DW 3000 is breaking the classic boundaries of the hot-air tool market, making it the lightest and most ergonomic in its class.

The power, precision, and control of the DW 3000 comes from a brushless motor powered by next-gen electronics. The next-gen electronics provide the DW 3000 its unique features and also make it possible to precisely control the power and heat of the tool. The revolutionary hot-air tool by Sievert.

DW 3000

DW 3000

VANTAGGI

- Sensore temperatura
- Bocchettone arieggiato
- Raffreddamento automatico
- Motore brushless
- Leggerissimo
- Memory system
- Elettronica di nuova generazione
- Filtro d'aria removibile
- Schermo LED antiriflesso e lettura voltaggio

ADVANTAGES

- Temp sensor
- Air cooling nozzle
- Automatic cool down
- Brushless motor
- Lightweight
- Memory system
- Next-gen electronics
- Detachable air filter
- Anti reflection LED and voltage readout



PRODOTTO / PRODUCT						
Codice Code	Tensione Voltage	Potenza Power consumption	Display e regolazione della temperatura Digital temperature display and adjustment	Quantità Aria Air Flow	Pressione Statica Static pressure	Pagina listino Price list page
M121293001	230 V	2000 W	SI YES	III 370 l/min II 340 l/min I 310 l/min	Pa 4100 Pa 3600 Pa 3100	50

ACCESSORI/ACCESSORIES		
Codice Code	Descrizione Description	Pagina listino Price list page
M121297101	Resistenza 230 V Heating Element 230 V	50
M121297150	Filtro rimovibile Air Intake	50



Ergonomia rivoluzionaria
Revolutionary Ergonomics



3 Livelli di regolazione flusso d'aria
Revolutionary 3 levels Air-flow



Accurata misurazione della temperatura
Revolutionary temperature precision



Gamma completa di rullini
Complete range of rollers



Gamma completa di beccucci
Complete range of nozzles



RULLINI E ACCESSORI PER LA SALDATURA

ROLLERS & WELDING ACCESSORIES

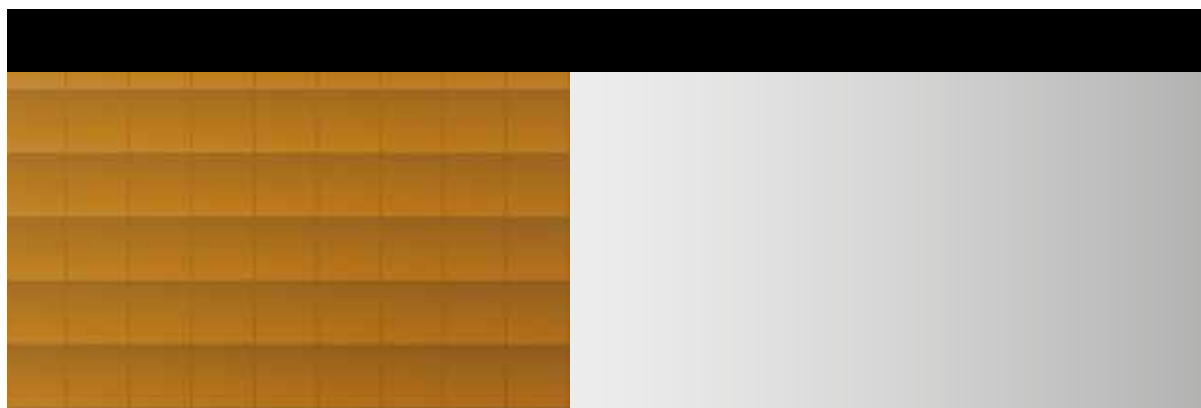

Cuscinetti a sfera per la massima scorrevolezza

Ball bearings



Impugnatura non verniciata per un'ottima presa e facile pulizia

Unpainted handle for good grip and easy cleaning



Silicone di alta qualità per la massima durata nel tempo

Highest quality of silicone for longlife

RULLINI IN SILICONE* SILICONE PRESSURE ROLLERS*



PRODOTTO / PRODUCT				
Codice Code	Ø, mm	Peso, g Weight, g	Modello Model	Pagina listino Price list page
M121297512	33 x 28	155	Dritto Straight	50
M121297513	33 x 45	240	Dritto Straight	50
M121297514	33 x 45	240	Angolo 45° Angolo 45°	50
M121297515	33 x 90	350	Dritto Straight	50

Rullini in silicone con cuscinetti per saldatura sovrapposta, asse rivettato, manico ergonomico in legno per la massima pressione, collegamento a un braccio. Fornito con gancio in plastica per appendere.

Silicone roller with ball bearings for overlap welding, screwed axis, ergonomical wooden handle for maximum pressure, bracketed on one side.

* Indicati per manti impermeabili in PVC
Specific for PVC membranes

RULLINI IN ACCIAIO* STEEL PRESSURE ROLLERS*



PRODOTTO / PRODUCT				
Codice Code	Ø, mm	Peso, g Weight, g	Modello Model	Pagina listino Price list page
M121297531	40 x 40	490	Dritto Straight	51
M121297532	40 x 60	625	Dritto Straight	51

* Indicati per manti impermeabili in bitume
Specific for bituminous membranes

Rullini in acciaio ultrasensibile per saldatura a freddo, due cuscinetti a sfera ultrasensibili, asse fissato con vite, manico ergonomico in legno per la massima pressione, collegamento a un braccio. Forniti con gancio in plastica per appendere.

Heavy duty steel pressure roller for cold pressure welding, Two smooth running ball bearings, riveted axis, ergonomical wooden handle for maximum pressure, bracketed on one side for overlap welding.

RULLINI IN PTFE* PTFE PRESSURE ROLLERS*



PRODOTTO / PRODUCT				
Codice Code	Ø, mm	Peso, g Weight, g	Modello Model	Pagina listino Price list page
M121297521	33 x 28	165	Dritto Straight	51
M121297522	40 x 60	625	Dritto Straight	51

* Indicati per manti impermeabili in TPO
Specific for TPO membranes

Rullini in PTFE antiaderente per saldatura sovrapposta, con due cuscinetti a sfera ultrasensibili, asse avvitato, manico ergonomico in legno per la massima pressione, collegamento a un braccio.

PTFE roller for overlap welding of much harder and tougher membranes such as polyolefin. Two smooth running ball bearings, screwed axis, ergonomical wooden handle for maximum pressure, bracketed on one side.

RULLINO IN METALLO
METAL PRESSURE ROLLERS



PRODOTTO / PRODUCT			
Codice Code	Ø, mm	Peso, g Weight, g	Pagina listino Price list page
M121297541	34 x 6	195	51

Rullino in metallo, con cuscinetto a sfera ultrascorrevole, rotella sottile e convessa, manico ergonomico in legno per la massima pressione.

Extra thin metal pressure roller for PVC-sheets welding and flooring installation, enclosed smooth-running ball bearings, extra thin, convex metal roller, ergonomical wooden handle for maximum pressure.

RULLINO IN OTTONE
BRASS PRESSURE ROLLERS



PRODOTTO / PRODUCT			
Codice Code	Ø, mm	Peso, g Weight, g	Pagina listino Price list page
M121297542	28 x 6	145	52

Rullino in ottone, con cuscinetto a sfera ultrascorrevole, rotella sottile e convessa, manico ergonomico in legno per la massima pressione.

Brass pressure roller, enclosed smooth-running ball bearings, extra thin, convex brass roller, ergonomical wooden handle for maximum pressure.



UNCINO PER TEST SALDATURE SEAM TESTER



PRODOTTO / PRODUCT			
Codice Code	Ø, mm	Peso, g Weight, g	Pagina listino Price list page
M121297551	250	100	52

Uncino a 90° per test saldature, impugnatura in legno ergonomica, punta ottimizzata.

90° angled seam tester, ergonomical wooden handle, optimized tip.

UGELLI NOZZLES



M121297305 M121297320 M121297321 M121297322 M121297340 M121297380

PRODOTTO / PRODUCT				
Codice Code	Descrizione Description	Dimensione Dimension	Peso, g Weight, g	Pagina listino Price list page
M121297305	Ugello cilindrico Reduction nozzle	Ø 5	42	52
M121297320	Angolare 15° Angled 15°	20 x 2	44	52
M121297321	Angolare 60° Angled 60°	20 x 2	45	52
M121297322	Angolare 90° Angled 90°	20 x 2	45	52
M121297340	Ugello piatto Straight nozzle	40 x 2	52	52
M121297380	Ugello piatto Straight nozzle	80 x 2	92	52

Ugelli di elevata qualità per saldatori ad aria calda Sievert. Realizzati in acciaio inox. Diametro attacco universale 32 mm. Forniti in blister appendibile.

High quality nozzles for Sievert hot air tools. Stainless steel. Universal 32 mm diameter. Delivered in PET blister pack.

TW 5000
SALDATURE CONTINUE
DI GRANDE QUALITÀ

TW 5000
HIGH QUALITY
WELDING RESULT



Sievert TW 5000 è stata progettata per soddisfare le esigenze progettuali degli applicatori. E' la macchina elettronica per saldare più versatile, affidabile, potente e facile da utilizzare attualmente presente sul mercato.

TW 5000 è in grado di saldare membrane in TPO, PVC, TPE e in bitume modificato SBS e APP. Questa nuova macchina elettronica per saldare è molto semplice da utilizzare e nasce dalla combinazione tra la grande esperienza Sievert nella realizzazione di prodotti per la copertura e la progettazione secondo i più moderni dettami tecnici.



The Sievert TW 5000 was designed with the contractor in mind. It is the most versatile, reliable, powerful and easy to operate automatic hot-air welding machine available on the market.

The Sievert TW 5000 can weld any membrane, such as plastic, rubber and modified bitumen. Sievert's long experience in making heating tools for the roofing industry together with new modern industrial design has created a truly professional and user friendly welding machine.

TW 5000

TW 5000



Le quattro ruote e il sistema cingolato assicurano una saldatura priva di grinze. La forza del motore ed il sistema di guida permettono di eseguire saldature sino a 30° di pendenza. Dotata di rotelline per agevolare il trasporto.

Four-wheel drive and belt system assures wrinkle-free welding. Powerful engine and efficient drive system allows climbing ability up to 30°. Separate free rolling wheels for easy transport.



Pannello di controllo molto facile da utilizzare. Display digitale che mostra temperatura, velocità e voltaggio. Funzionamento a 400 V o 230 V. Tutta la componentistica elettronica è realizzata in accordo con i più alti standard realizzativi industriali.

Easy to operate display unit. Digital display showing temperature, speed and incoming voltage. Runs on 400 V or 230 V. All electronics are made in accordance to highest industrial standard.



Potente flusso d'aria per la saldatura ad alta velocità. Impugnatura regolabile realizzata in acciaio robusto. Sensore per accensione e spegnimento automatico quando il convogliatore dell'aria calda viene attivato/disattivato.

Powerful fan for high-speed welding. Adjustable handle made of sturdy steel. Automatic start/stop sensor when the hot-air nozzle is engaged/disengaged.

PRODOTTO / PRODUCTS

Temperatura Temperature	40°C - 650°C completamente regolabile 40°C - 650°C fully adjustable
Lunghezza Cavo, cm Cable length, cm	90
Velocità Speed	0 - 7m/min completamente regolabile 0 - 7m/min fully adjustable
Display Display	LED
Flusso Aria Air flow	0 - 48 l/s completamente regolabile 0 - 48 l/s fully adjustable
Livello Rumore Emission level	70 dB
Dimensioni, cm Size, cm	56 x 38 x 25
Peso, Kg (incl. 8 kg) Weight, Kg (incl. 8 kg)	30
Dichiarazione di Conformità Declaration of conformity	CE

MODELLO 2990
MODEL 2990

Ideale per la saldatura delle sovrapposizioni nelle membrane in PVC e simili

Overlap welding of PVC and similar roofing membranes



Saldatura membrane plastiche
Plastic welding



PRODOTTO/PRODUCTS							
Codice Code	Voltaggio Voltage	Consumo Power	Amperaggio Ampere	Frequenza Frequency	Larghezza Beccuccio, mm Nozzle width, mm	Larghezza giuntura saldabile, mm Width of welding seam, mm	Pagina listino Price list page
M121299001	400 V	6300 W	16 A	50 - 60 Hz	55	40 - 55	53
M121299005	220 - 230 V	5000 W	22 A	50 - 60 Hz			53
M121299047	220 - 230 V	6300 W	28 A	50 - 60 Hz			53

MODELLO 2991
MODEL 2991

Ideale per la saldatura delle sovrapposizioni di membrane in bitume modificato e simili

Overlap welding of modified bitumen and similar roofing membranes



Saldatura bitume modificato
Modified bitumen welding



PRODOTTO/PRODUCTS							
Codice Code	Voltaggio Voltage	Consumo Power	Amperaggio Ampere	Frequenza Frequency	Larghezza Beccuccio, mm Nozzle width, mm	Larghezza giuntura saldabile, mm Width of welding seam, mm	Pagina listino Price list page
M121299101	400 V	6300 W	16 A	50 - 60 Hz	90	70 -100	53



BOCCHETTONI
ANGOLARI IN TPE
RACCORDI PER
BOCCHETTONE
ANGOLARE

PAG
50

TPE ANGULAR
DRAINS - PIPE
ADAPTORS FOR
ANGULAR DRAIN

BOCCHETTONE
ANGOLARE PER
POGGIOLI

PAG
53

ANGULAR
DRAIN FOR
BALCONIES

PAG
40

BOCCHETTONE CON
SCARICO VERTICALE O
LATERALE IN TPE

TPE ROOF DRAIN
WITH SIDE OR
VERTICAL EXIT





PAG
34

BOCCHETTONE
"GENIUS" IN TPE

ROOF DRAIN "GENIUS"
MADE OF TPE

PAG
22

BOCCHETTONI "REVOLUTION"
IN MEMBRANA BITUMINOSA
POLIMERICA

"REVOLUTION" ROOF
DRAINS MADE OF
POLYMERIC BITUMINOUS
MEMBRANE

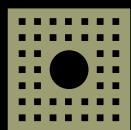

ETERNO



MASTER

Plastic+
Group

PLASTIC
PLANET

Italtronic

eterndivica

Concept & Art Direction: Dnart srl - Firenze
3D real vision design: Dnart srl - Firenze
Communication design: Dnart srl - Firenze
Print typography: Tipografia Toffanin - Padova

Nessuna parte di questa brochure può essere riprodotta in qualunque forma senza autorizzazione di Eterno Ivica s.r.l.
All right reserved. No part of this publication may be reproduced in any form without prior permission from Eterno Ivica s.r.l.



eternoivica
WWW.ETERNOIVICA.COM